

## A COMPLETELY INTRAMEDULLARY LEG LENGTHENING DEVICE

A.M.M. Aalsma\*, E.E.G. Hekman\*, J. Stapert\*\*, H. Grootenboer\*.

\* Laboratory for Biomechanical Engineering, Dept. of Mechanical Engineering, University of Twente, Enschede, The Netherlands.

\*\* Dept. of Medicine, The Universiteit Maastricht, Maastricht, The Netherlands.

\*E-mail: a.m.m.aalsma@wb.utwente.nl

**Abstract**—The procedure and the external fixator for lengthening long bones was developed by G. A. Ilizarov in the late 1960's. This technique has, despite its proven abilities for leg lengthening and correction of angular deformities, some considerable disadvantages for the patients. Discomfort, infections and restricted weight bearing are some reasons for the development of a completely intramedullary device for leg lengthening. The device developed at the Laboratory of Biomechanical Engineering, University of Twente, is a telescopic intramedullary nail with a maximum diameter of 13 mm, which can be lengthened with 0.5 mm steps induced by a Shape Memory Alloy Actuator. The electrical energy for the actuator is supplied from outside the body by inductive coupling of two solenoid coils. Internally, the electrical energy is transformed to thermal energy by Thermofolios and Peltier-elements.

### I. INTRODUCTION

In the 1960's the Russian scientist G. A. Ilizarov developed a clinical procedure to lengthen long bones like the tibia and the femur. This procedure starts with an osteotomy of the bone, followed by distraction at a certain rate of the fresh callus tissue that forms in the osteotomy. This callus distraction will result in the formation of new bone tissue (osteoneogenesis) as long as a mechanical stress is applied on the callus. The optimum distraction rate is approximately 1mm/day, starting about 9 days after the osteotomy [1]. The tool that Ilizarov designed to perform the distraction and angular corrections of long bones (the Ilizarov fixator) is an external frame around the limb, which is connected transcutaneously to the bone by screws or wires. Distraction is carried out by manually turning knobs on the frame. The Ilizarov fixator and variants are still being used in modern surgery. The procedure to install the fixator is relatively simple but time consuming. The medical results are satisfactory and the fixator enables simultaneous elongation and correction of angular deformities of the bone. However, the Ilizarov fixator has its disadvantages:

- Pin/wire Track infection.
- Bone infection caused by the pins or wires

- Damage to soft tissue, muscle and possible nerve damage by the transcutaneous pins/wires during elongation.
- Contraction of the joints.
- Long period of wearing the fixator, since it also stabilizes the fracture after elongation.
- Discomfort to the patient caused by the weight and size of the fixator and complication of normal functioning in the patient's daily environment.

A first improvement for normal lengthening has been made by the use of a unilateral fixator. A further enhancement is combining the unilateral fixator with an intramedullary locking nail [2] where the position of the bone parts is defined by the intramedullary locking nail, while the fixator is used for distracting the bone. The advantages of the latter system are shorter presence of an external fixator, because it can be removed after the elongation period, and the superior positioning and stability of the bone before and after removal of the external fixator so the patient can start using the limb sooner. The disadvantages are still pin track infection, tissue damage and restricted weight bearing during elongation. At the Laboratory for Biomechanical Engineering of the University of Twente a fully implantable extractor [3] is designed for normal leg lengthening. This extractor is placed entirely in the medulla of the bone (maximum diameter of 13 mm) without transcutaneous connections or subcutaneous parts. Advantages of this extractor are:

- No transcutaneous connections and therefore less risk on infection.
- The absence of the pins or screws also lessens the risk of soft tissue damage, muscle and nerve damage.
- Reduction of joint contraction.
- High axial stability, comparable to the standard intramedullary locking nails.
- Easy implantation procedure, comparable to the standard intramedullary locking nails.
- Full weight bearing possible shortly after surgery
- No discomfort of an external frame mounted to the leg.

This paper will give a short description of the proposed design.

\* Address correspondence to: A.M.M.Aalsma, Dept. of Mechanical Engineering, Laboratory of Biomechanical Engineering, University of Twente, P.O. Box 217, 7500 AE Enschede, The Netherlands.

## II. THE DESIGN

The design of the intramedullar elongation device consists out of four main parts: an actuator, temperature control devices, an energy supply system and a telescopic nail.

### A. The Actuator

To increase the safety and durability of a mechanical system it has to be as simple as possible. Reducing the number of moving parts will result in less wear and a lower chance of failure. From this point of view most conventional and formerly proposed solutions for actuators are not usable. By using a Shape Memory Alloy (SMA) like NiTiCu, an actuator with almost no mechanical wear can be constructed. SMA's have a high temperature phase (Austenite) and a low temperature phase (Martensite). The temperature range in which the phase transitions take place is about 30 °C depending on the composition of the SMA (figure 1).

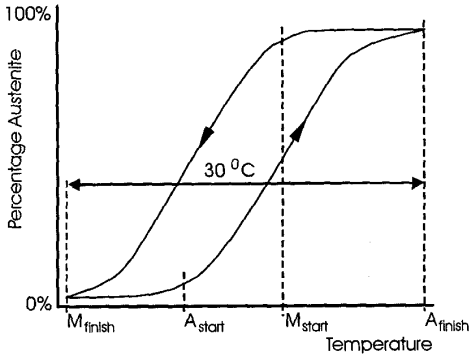

Figure 1: Transition trajectory for a typical NiTiCu SMA. The phase transition from Martensite to Austenite takes place within 30 °C. There is a hysteresis in the transition temperatures between  $M_{finish}$  to  $A_{finish}$  and from  $A_{finish}$  to  $M_{finish}$ .

Each phase has its own crystal structure and its own mechanical properties. The change of microstructure during phase change can be used, if "trained" properly, to give each phase its own particular shape. This latter property is called the Two Way Shape Memory Effect (TWSME) [4]: alternating temperatures will yield the alternating shapes. The location of the transition temperatures on the temperature-scale like in figure 1 can be influenced by alloy composition, mechanical treatment and heat treatment. The training used to induce the TWSME is "Training by constrained Temperature Cycling of Deformed Martensite" [4]: first the SMA object is deformed in its Martensitic phase to just below the point of plastic deformation. Next, the component is heated to the Austenite phase while deformation is held and subsequently cooled to back the Martensite phase. This temperature cycle is repeated 30

times to get a stable TWSME. The shape change in the direction of the training to 1.5%-2% of the original dimension.

The SMA actuator consists of two rings and a tube made of NiTiCu. Both rings and tube have been trained for TWSME. The tube is trained in its axial dimension and will change its length upon heating or cooling. This will induce the actual lengthening step. The rings are trained to have a change in diameter. In their Austenite phase, the rings will have the smallest diameter and will clamp to the central pin. One of the rings will be clamped to the pin at body temperature and is responsible for the locking the telescopic nail during normal situations. This ring can be loosened by cooling. The other ring, being in its Martensitic phase at body temperature, can be clamped by heating. When the elements are activated in a certain sequel, the actuator can make small steps along a central pin and generate a force in its direction of movement (figure 2).

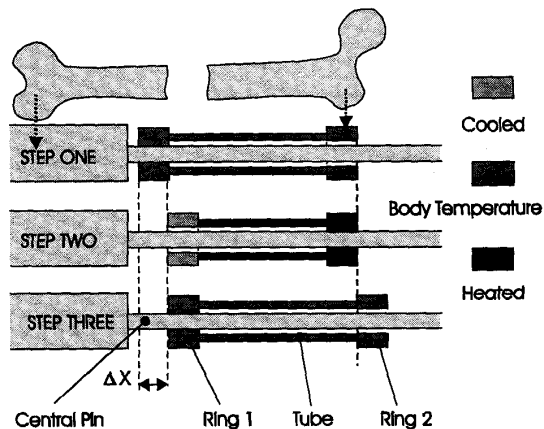

Figure 2: Simplified step sequence for the SMA Actuator. Step Two will be divided in a number of steps to make sure that there is always one ring clamped to the central pin.

### B. Temperature-Control Devices

The TWSME of the elements is temperature controlled. Phase change, ea. shape change and force generation, takes place within a certain temperature range. To loosen the ring that is clamped to the pin at body temperature, it has to be cooled below the Martensitic Transformation finish temperature ( $M_f$ ). Peltier elements, which are miniature solid state heat pumps, are used for this task (figure 3). For heating the tube and the other ring thin resistance foils (ThermoFoil) are used. An electronic timer device or sequencer will generate the sequence in time for activation of the heating and cooling devices after receiving a start signal from the primary coil of the energy transport system.

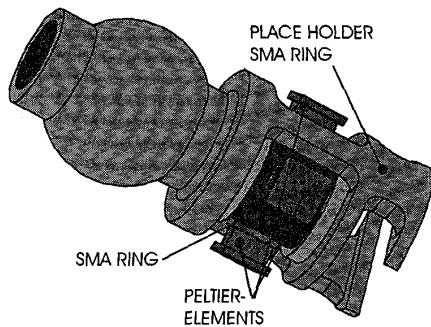

Figure 3: Place holder for SMA Ring with Peltier Cooling Devices. The holder connects the ring with the tube.

### C. Energy Transport System

From the perspective of safety and space, the choice is made not to store the entire energy supply needed for an average lengthening of 30 mm in the pen. The energy for the temperature-control devices and the sequencer will be supplied from outside the body by inductive coupling of two solenoid coils. A secondary coil will be built into the lengthening device while a primary coil can be fitted around the patient's leg during the lengthening procedure (figure 4).

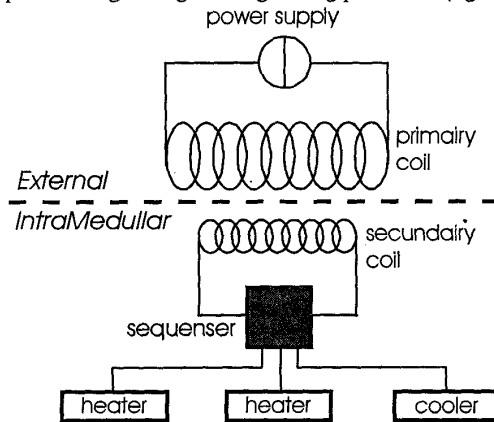

Figure 4: Schematic representation of the energy transmission and distribution of the current to the temperature control devices.

Although solenoid coils have low transmission efficiency compared to for example two planar coils just underneath the skin, the advantage is the absence of subcutaneous parts. The energy transmission efficiency  $\eta$  is defined as:

$$\eta = \frac{\text{output power}_{\text{coil2}}}{\text{input power}_{\text{coil1}}} \times 100\%$$

The efficiency  $\eta$  is a critical point: if it is too low, the electrical current through the primary coil will become too

high and will heat the coil enough to make skin contact impossible. To increase efficiency the two coils have to be tuned to a resonance frequency, and the secondary coil needs a core of a ferromagnetic composition.

### D. The Telescopic Nail

The telescopic nail has two functions. The first is housing and protecting the actuator and the electronics (figure 5). These parts will be shielded from direct contact with the bone. This way the heat generated by the actuator will be dissipated over a larger area before it reaches any living tissue. The second function is to guide the torsional and bending forces. The actuator is coupled to the nail in such a way that it can only transfer axial forces. Both ends of the telescopic nail are connected to the bone halves with the standard methods for locking nails.

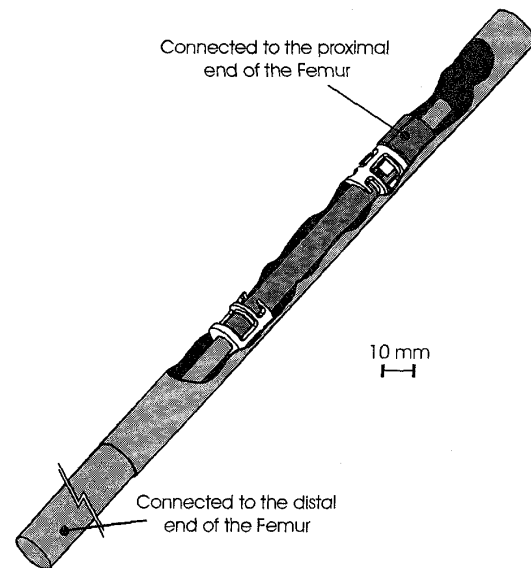

Figure 5: Cut through drawing of the Telescopic Nail with the SMA Actuator inside. The upper part of the Telescope is connected to the Actuator and the proximal end of the Femur. The lower part is part of the central pin and is connected to the distal end of the Femur.

## III. RESULTS

The important elements have been tested and the results are given in the following paragraphs. A fully functional prototype is expected in July 1998.

### A. The SMA rings

Twelve rings of NiTi were produced and tested on shape change and clamping force [5]. All rings had the same dimensions of inner diameter  $D_i = 5$  mm, outer diameter

$D_o = 7$  mm and height  $h = 2$  mm. The final rings will have a height of 5 mm. The rings were trained for TWSME by “Constrained Temperature Cycling of deformed Martensite”. Deformation was accomplished by forcing the rings on a conical pin until the diameter was increased by 5.5%. In this deformed state the rings were heated and cooled in the thermostatic baths at 100 °C and 0 °C for 30 times. The shape change of inner diameter after TWSME training was  $\approx 1.5$  %. The maximum axial load depends on the training method and the margin between the pin and  $D_i$  before clamping. With a useful margin, easy free movement before clamping, the axial bearing load was 4100 N (figure 6). Shape change and axial bearing load are sufficient for the design.

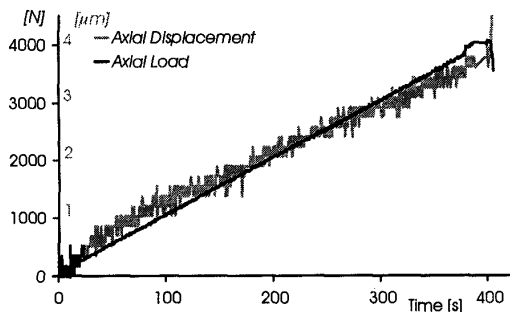

Figure 6: Gradual increase in time of axial load on the clamped ring until it starts slipping over the pin at 4100 N.

#### B. The SMA Tube

A tube with an inner diameter  $D_i = 5.5$  mm, outer diameter  $D_o = 7$  mm and height  $h = 50$  mm was tested on the TWSME in the axial direction. The training method used was “Training by Constrained Temperature Cycling of Deformed Martensite”. A martensitic NiTiCu rod was stretched 10% in a Zwick testing facility with a thermo controlled room installed between the clamps. While the deformation was held, the temperature alternated 30 times between 0°C and 100°C. After the training tubes were made from this rod by spark erosion. The results on shape change of the tubes are  $\approx 2$  % axial length change and a force generation during shape change of 1300 N.

#### C. Energy Transport System

For the tests two solenoid coils were used. Primary Coil 1 with  $L_1=250$  mm and  $D_1=250$  mm and secondary Coil 2 with  $L_2=100$  mm and  $D_2=12$  mm. Tested were the influence on the efficiency  $\eta$  of radial position of the coils, influence of a ferromagnetic core in Coil 2 and tuning of the coils. Efficiency  $\eta$  varied from 5% for radial aligned coils without core to 25% for radially aligned coils with core and tuning to the resonance frequency. Efficiency decreased when the coils were not radial aligned, but misalignment caused by the anatomical proportions of the lower and upper limbs are

acceptable. The tests showed that it was possible to generate 10 Watts in Coil 2 with 25% efficiency.

#### IV. DISCUSSION

The first point of attention in the proposed design is the shifting of the transformation temperatures of the NiTi after training. It would be useful to fully investigate the relation between temperature shift and training procedure to be able to make an accurate prediction of the final transformation temperatures. The body can withstand only a relatively small diversion of the normal body temperature. Therefore it is important to have the exact transformation temperatures of the SMA to take full advantage of this narrow permissible temperature range without damage to any tissue.

Another point of attention is the energy transmission. For the highest efficiency, the two coils should be trimmed to a certain resonance frequency. This frequency is specific for the given combination of coils and capacitors. If the heating/cooling device contains some capacitance or inductance the setup has to be tuned again during changing from heating to cooling. An active filter, which complicates the electronic circuitry, can perform this task or standardizing each load to equal capacitance and inductance, which means energy losses.

The next step in this design is in-vitro tests of the first prototype under a simulated environment, comparable to the human body. Challenges to be expected are the thermal and electrical isolation of the devices from the body fluids for a longer period.

*Acknowledgment*—The Authors wish to thank Dr. J. Beijer and Dr. J. Maas, Lab. of Material Science, Dept. of Mechanical Engineering, University of Twente Enschede for providing testing facilities and knowledge on SMA’s. This Research is funded by the Dutch Technology Foundation STW.

#### REFERENCES

- [1] Ilizarov G.A., *Clin. Orthop.*, **250** (1990) 8.
- [2] Raschke M.J., Mann J.W., Oedekoven G. and Claudi B.F., *Clin. Orthop.*, **282** (1992) 233.
- [3] Aalsma A.M.M., Hekman E.E.G., Stapert J.W.J.L., Grootenboer H.J., Inrichting voor het onderling verplaatsen van twee objecten, Ned Octrooi, No. 1004873, (Bureau voor Ind. Eigendom, Rijswijk, 1996).
- [4] Duerig T.W., Melton K.N., Stöckel D. and Wayman C.M., *Engineering aspects of Shape Memory Alloys* (Butterworth-Heinemann, London, 1990) pp. 200-206.
- [5] A.M.M. Aalsma, E.E.G. Hekman, J.W.J.L. Stapert, H.J. Grootenboer., *J.Phys. IV France*, **627** (1997) 7.