

OYSTER[®] ACIF

INSTRUMENTATION GUIDE

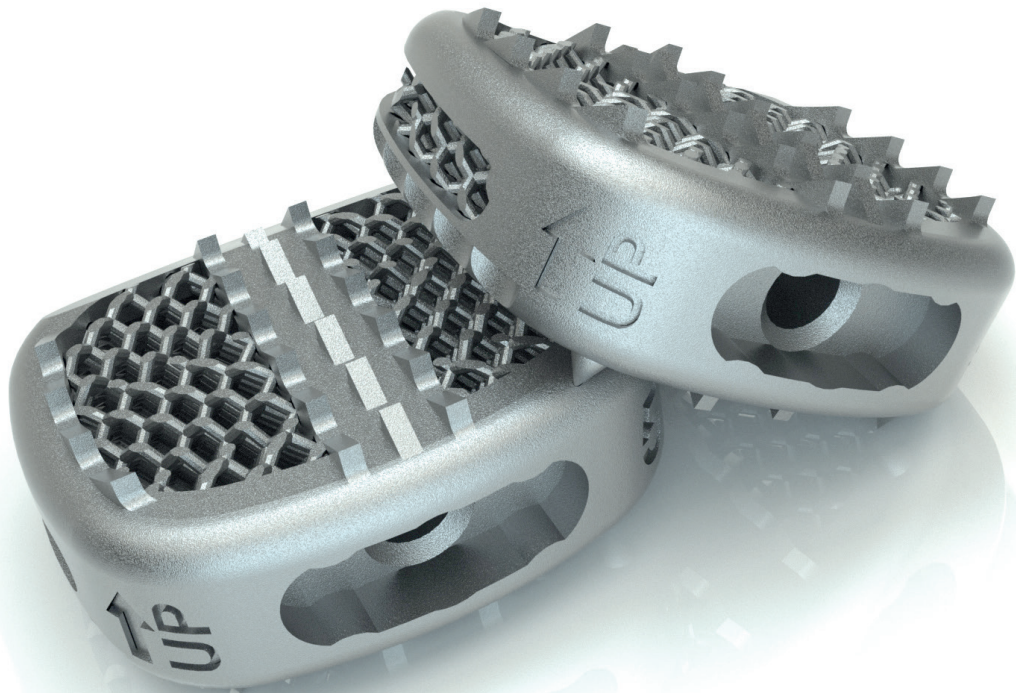

TABLE OF CONTENTS

Intended use	3
Indications	3
Contraindications	3
Warnings	4
Oyster ACIF – Instrumentation	5
PRODUCT INFORMATION	15
Oyster ACIF Implants	PI 02
Oyster ACIF Trial Implants	PI 04
Oyster Instruments	PI 05

Intended use

The Oyster cages are cervical interbody fusion cages and have been developed for anterior single or multi-level interbody fusion. They are intended for insertion between two adjacent cervical vertebrae in skeletally mature patients. In combination with autograft or allograft the Oyster cages restore the intervertebral height of the spinal segment and facilitate osteosynthesis. Additional stabilization with a plate system is recommended.

See also the WARNINGS in this instrumentation guide.

Indications

The Oyster ACIF cage is intended for the treatment of:

- Degenerative disc disease (DDD)
- Prolapsed intervertebral disc and symptomatic cervical spondylosis
- Spondylotic myelopathy and foraminal stenosis
- Spine trauma, lesions and revision surgeries

Contraindications

Contraindications may be relative or absolute. The selection of a particular implant must be carefully weighed against the anamnesis of the patient. The following circumstances may reduce the success of the treatment:

- Implantation in patients with an active infection or pronounced local inflammation in the area of surgery
- Severe osteoporosis affecting the spine
- Primary or metastatic tumors affecting the spine
- Suspected allergy or foreign body reaction to titanium or titanium alloys
- Patients whose ability to follow postoperative restrictions, precautions and rehabilitation programs is limited
- Fractures, severe deformities or an instability in the area of surgery

In addition, it has been shown that smoking has an increased incidence of pseudarthrosis.

Adverse events

Potential risks identified with the use of this system include:

- Device fracture
- Loss of fixation
- Nonunion
- Implant subsidence
- Neurologic injury and/or vascular/visceral injury
- Infection
- Postoperative migration of the implant
- Intolerance to the material

Further adverse events identified, not directly linked to product or procedure, are:

- Degeneration of the vertebrae adjacent to the arthrodesis

MRI SAFETY A patient with this implant/device can be scanned safely immediately after placement under the following conditions:

- Static magnetic field of 3-Tesla or less
- Maximum spatial gradient magnetic field of 720-Gauss/cm (a higher value for the spatial gradient magnetic field may apply if properly calculated).
- Maximum MR system reported whole-body-averaged specific absorption rate (SAR) of 2 W/kg for 15 minutes of scanning (per pulse sequence).

In all cases, the Health Care Professional is responsible for MR Conditions, MR Imaging quality and patient safety. Any safety issues or major image artefacts should be reported.



MRI-Related Heating

In non-clinical testing, comparable devices produced a temperature rise of less than or equal to 6.0 degrees °C using an MR system reported, whole body averaged specific absorption rate (SAR) of 2 W/kg for 15-minutes (per pulse sequence) of scanning in a 3-Tesla MR system.

Artifact

MR image quality may be compromised if the area of interest is in the exact same area or relatively close to the position of the implant/device. In some cases, the artifact size relative to the size of the implant or device may be indicated.

Attention: Contact the manufacturer of this implant/device for further information, as needed.

OYSTER[®] ACIF INSTRUMENTATION

Pre-surgical planning

Perform appropriate patient selection and inform patient of limitations and potential adverse effects of the surgery. Patients must be skeletally mature and have had at least six months of non-operative treatment. Ensure implants and the designated instrument set are available and ready for use (see Instructions for Use for cleaning and sterilization instructions of the instruments).



PATIENT SELECTION Appropriate patient selection is critical to the surgical outcome. Only patients who satisfy the indications AND who do not have any of the contraindications should be considered for interbody fusion surgery using the Oyster ACIF cage to avoid adversely affecting device performance or surgical outcome.



INSTRUMENTS Only use instruments and accessories listed in the surgical technique to avoid adversely affecting device performance or surgical outcome. The surgical team must verify that the instruments are in good condition and in operating order prior to use during surgery.



PATIENT EDUCATION Preoperative instructions to the patient are essential. The patient should be made aware of the limitations and potential adverse effects of the surgery. The patient should be instructed to limit the postoperative activity as this will reduce the risk of bending, breaking and/or loosening the implants. The patient must be made aware that implant components may bend, break and/or loosen, even though restrictions in activity are followed.



INTENDED USERS The surgeon should strictly follow the recommendations in the surgical technique and all staff involved should be familiar with the surgical procedures associated with the cervical interbody fusion technique to avoid adversely affecting device performance or surgical outcome.

Surgical steps

PREPARATION AND APPROACH

Place the patient on the OR table using the standard positioning in cases of anterior cervical interbody fusion. Make sure to allow for X-ray examinations by C-arm. Confirm the affected level(s) using imaging techniques and perform a standard anterior cervical approach.

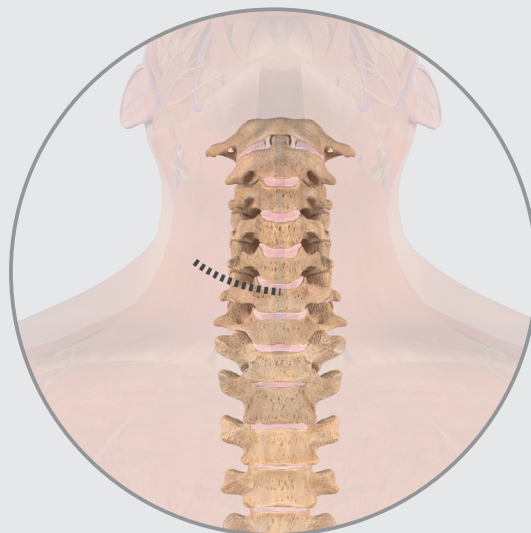
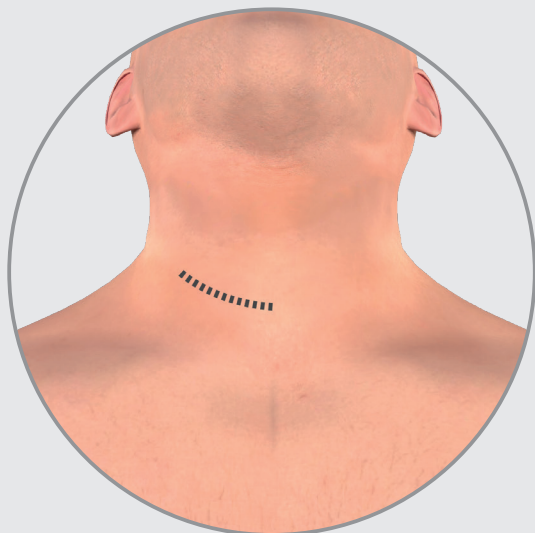

DISTRACTION

Distract the vertebrae in accordance with Caspar distractor IFU.



DISTRACTION Adequate distraction is one of the preconditions for the primary stability of the implant; however, it is critical to ensure that the segment is not over distracted to avoid damage of ligaments and/or endplates.

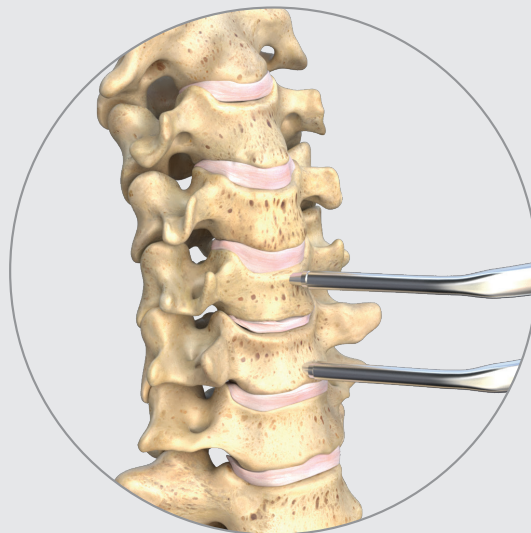
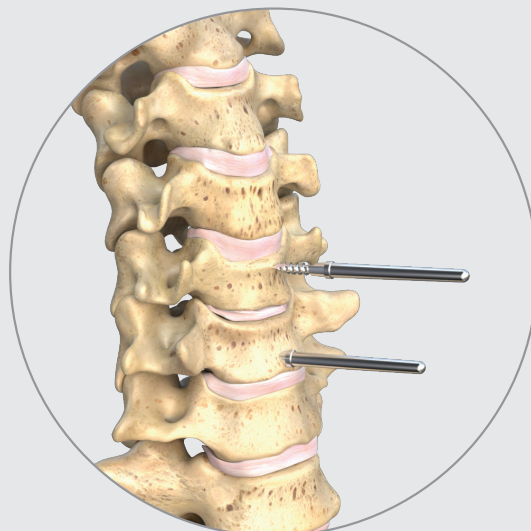

Surgical steps

DISCECTOMY AND CURETTAGE

Resect the anterior anatomy and perform the intervertebral discectomy. Perform discectomy with standard instruments and expose the bony endplates.

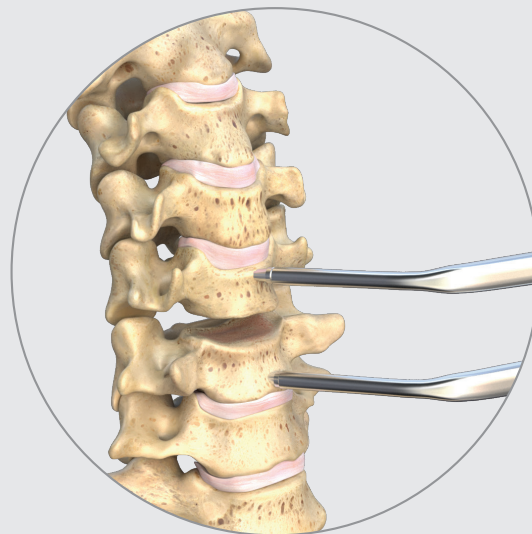

ENDPLATE PREPARATION Appropriate removal of the cartilaginous layers of the endplates is important for the vascularization of the bone graft. However, make sure to clean the endplates carefully and maintain the integrity of the underlying bony endplate, as damage of the endplate can lead to implant subsidence.

Trial insertion and determination of cage size

Attach the Trial sizer to the Inserter. Align the front of the Trial sizer with the tip of the inserter and make sure the tip slides into the openings of the interface. Rotate the knob at the back clockwise until the Trial sizer is securely seated in the tip of the inserter.

Insert the Trial sizer with gentle taps on the back of the handle until it is fully seated in the intervertebral space. Start with a small size and repeat using the next larger size, sequentially until the Trial sizer fits tightly in the disc space and the nerve roots are adequately released. Check the secure fit and final position of the trial with fluoroscopy. Remove the Trial after cage size determination.

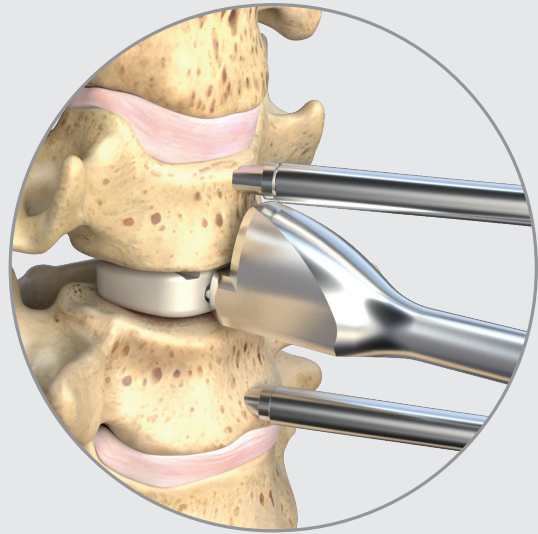

INSERTION DEPTH Insertion shall be performed under fluoroscopy control to avoid too deep placement resulting in spinal cord injury.



SIZE SELECTION The Oyster ACIF cages are available in a wide variety of sizes to ensure appropriate sizing of the implanted components. Correct size selection is critical to the surgical outcome. An under- or oversized implant can lead to premature failure of the cage.

Implant insertion

Use standard aseptic practice to open the sterile packaging of the implant size that was determined with the Trial. Attach the implant to the inserter, according to surgeon preference the inserter with (BM-OINSS) or without (BM-OINS) depth stop can be used¹. Align the front of the implant with the tip of the inserter and make sure the tip slides into the openings of the implant interface. Rotate the knob at the back clockwise until the implant is securely seated in the tip of the inserter.

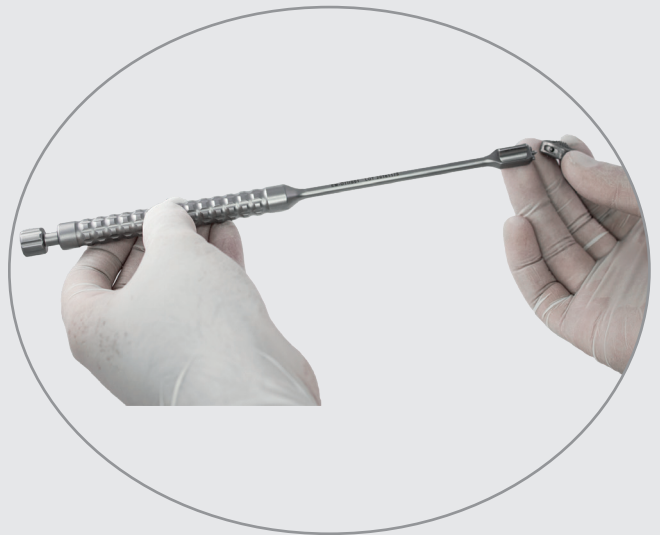
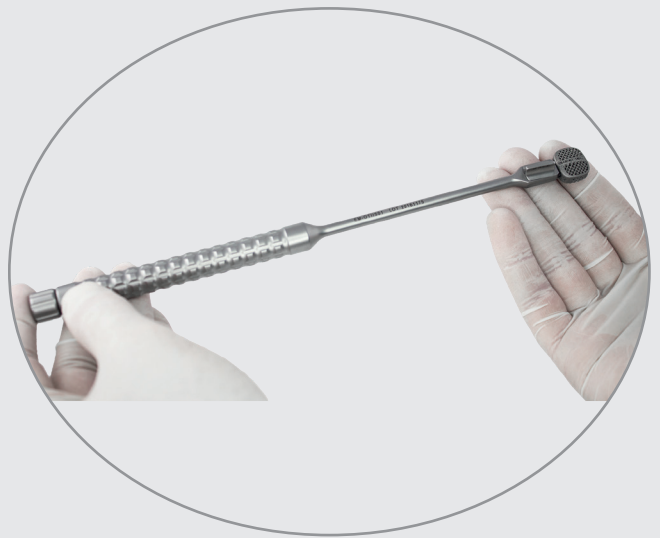

¹To assemble the inserter, screw the pin (BM-OINSP) in the tube (BM-OINSTS or BM-OINST) until the tip of the pin protrudes the distal part of the outer tube. Disassemble the inserter prior to cleaning: turn the pin counter clockwise and remove the pin from the outer tube.

Implant insertion

Bone graft and/or bone graft substitute might be added into the cage. Add this after attachment of the inserter, to avoid bone graft build up in the implant-inserter interface hindering a proper implant-inserter attachment.

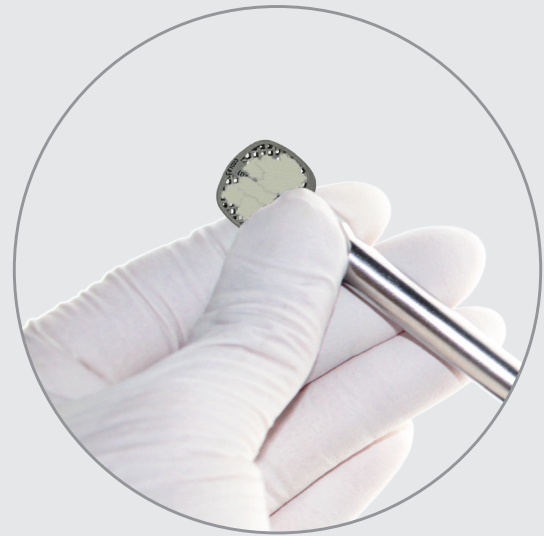

USE-BY DATE AND STERILITY Before using the Oyster ACIF cage check the use-by date (YYYY/MM/DD) on the packaging. Do not use the implant after the use-by date, this can lead to infection.



PACKAGING INTEGRITY Before use of the Oyster ACIF cage check the secondary packaging, labelling and sterile primary packaging are intact. The sterile packaging should be free of cracks, holes, tears and any other damage. Use of an Implant from a damaged packaging can lead to an untraceable product or infection.



IMPLANT HANDLING The cages should be handled appropriately to protect them from unintentional damage. Avoid scratching or damaging the cage at any time (specifically during attachment of the implant to the inserter and implant placement), as this may lead to premature failure of the cage. Do not use damaged implants.

Implant insertion

Insert the implant with gentle taps on the back of the inserter until the implant is in the intervertebral space.

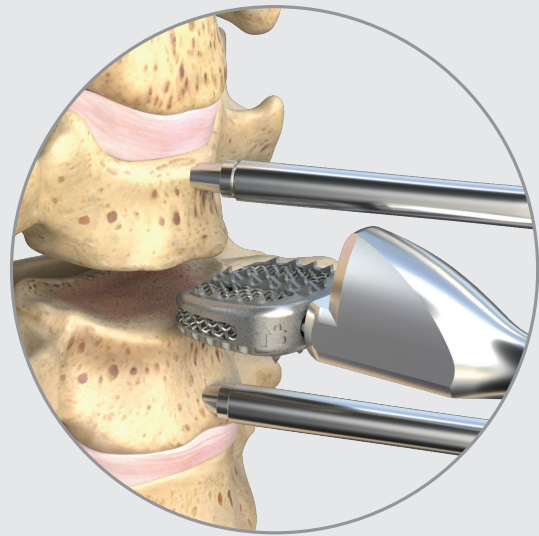

INSERTION DEPTH Insertion shall be performed under fluoroscopy control to avoid too deep placement resulting in spinal cord injury.



IMPLANT PLACEMENT The cage has teeth to maximize primary stability, however make sure the soft tissues are adequately retracted when inserting the implant to avoid damage from contact with the cage (in particular the rough cranial and caudal surfaces). Adequate implant positioning is critical; an improperly placed implant can adversely affect device performance or surgical outcome.

Implant insertion

Check the secure fit and final position of the implant with fluoroscopy. If the implant position is adequate, remove the inserter by rotating the inserter knob counter clockwise. Remove the Caspar pins.

Depending on surgical preference, the disc space can be filled prior to and after cage implantation with remaining bone graft and/or bone graft substitute. It is recommended to place an anterior plate system in accordance with the corresponding surgical technique.

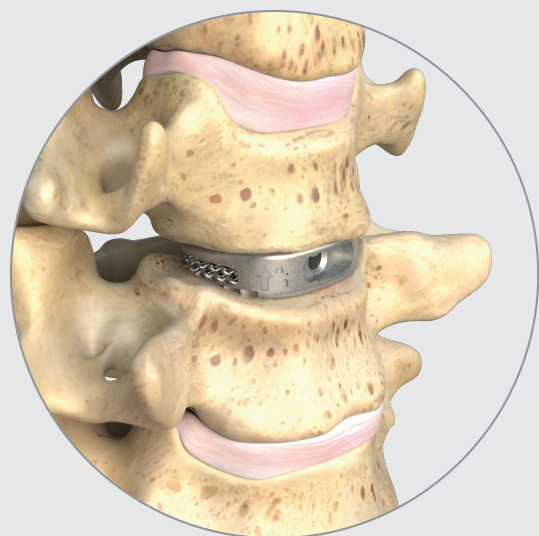
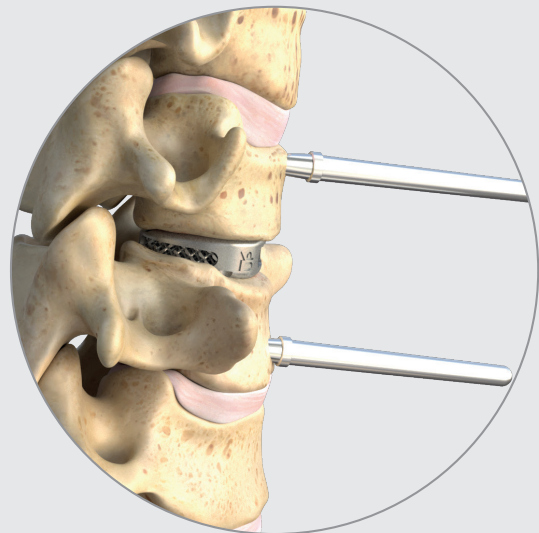
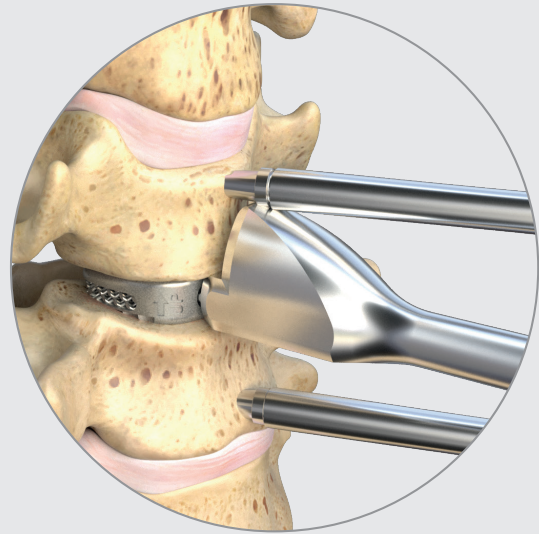

Implant removal; Postoperative; Disposal

Implant removal

The Oyster ACIF cage is intended for permanent implantation and is not intended to be removed in case of a good outcome. However, adverse events might warrant removal of the implant.

Dissect the bone, attach the inserter to the implant and remove the implant.

Postoperative

The patient should be instructed to limit the postoperative activity as this will reduce the risk of bent, broken and/or loose implant components.

Postoperative evaluation of the fusion and the implant status are mandatory.

Disposal

The disposal of this medical product requires no special measures. Be sure to observe all national/local regulations and guidelines when disposing of the packaging material and potentially infectious items.



SINGLE USE ONLY The Oyster ACIF cages are provided as single use implants only, and are not to be reused, resterilized or reimplanted in any situation as this might adversely affect device performance and/or increase risk of infection.



PERMANENT IMPLANTATION The device is intended for permanent implantation and shall not be removed in case of good outcome. Removal of a stable implant can lead to loss of stability and damage to the surrounding tissue.

OYSTER[®] ACIF PRODUCT INFORMATION

Oyster ACIF Implants by article number	PI 02
Oyster ACIF Trial Implants by article number	PI 04
Oyster Instruments by article number	PI 05
General Instruments by article number	PI 05

Oyster ACIF Implants

Article number explanation for the cage, as an example

Oyster ACIF Cage, 16 x 17 x 5 dome closed

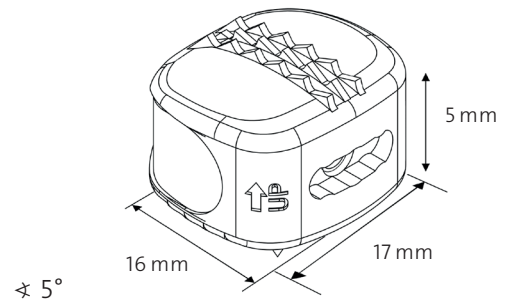
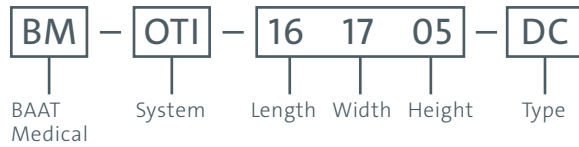

System:
Oyster

Implant type:
ACIF

Typing:
dome closed

Material:
Ti6Al4VELI

Article number	Description	Illustration
BM-OTI141504DC	Oyster 14 x 15 x 4 dome closed	
BM-OTI141505DC	Oyster 14 x 15 x 5 dome closed	
BM-OTI141506DC	Oyster 14 x 15 x 6 dome closed	
BM-OTI141507DC	Oyster 14 x 15 x 7 dome closed	
BM-OTI141508DC	Oyster 14 x 15 x 8 dome closed	
BM-OTI141509DC	Oyster 14 x 15 x 9 dome closed	

System:
Oyster

Implant type:
ACIF

Typing:
dome closed

Material:
Ti6Al4VELI

Article number	Description	Illustration
BM-OTI141704DC	Oyster 14 x 17 x 4 dome closed	
BM-OTI141705DC	Oyster 14 x 17 x 5 dome closed	
BM-OTI141706DC	Oyster 14 x 17 x 6 dome closed	
BM-OTI141707DC	Oyster 14 x 17 x 7 dome closed	
BM-OTI141708DC	Oyster 14 x 17 x 8 dome closed	
BM-OTI141709DC	Oyster 14 x 17 x 9 dome closed	

System:
Oyster

Implant type:
ACIF

Typing:
dome closed

Material:
Ti6Al4VELI

Article number	Description	Illustration
BM-OTI161704DC	Oyster 16 x 17 x 4 dome closed	
BM-OTI161705DC	Oyster 16 x 17 x 5 dome closed	
BM-OTI161706DC	Oyster 16 x 17 x 6 dome closed	
BM-OTI161707DC	Oyster 16 x 17 x 7 dome closed	
BM-OTI161708DC	Oyster 16 x 17 x 8 dome closed	
BM-OTI161709DC	Oyster 16 x 17 x 9 dome closed	

Oyster® ACIF Implants

System:
Oyster

Implant type:
ACIF

Typing:
flat closed

Material:
Ti6Al4VELI

Article number	Description	Illustration
BM-OTI141504FC	Oyster 14 x 15 x 4 flat closed	
BM-OTI141505FC	Oyster 14 x 15 x 5 flat closed	
BM-OTI141506FC	Oyster 14 x 15 x 6 flat closed	
BM-OTI141507FC	Oyster 14 x 15 x 7 flat closed	
BM-OTI141508FC	Oyster 14 x 15 x 8 flat closed	
BM-OTI141509FC	Oyster 14 x 15 x 9 flat closed	

System:
Oyster

Implant type:
ACIF

Typing:
flat closed

Material:
Ti6Al4VELI

Article number	Description	Illustration
BM-OTI141704FC	Oyster 14 x 17 x 4 flat closed	
BM-OTI141705FC	Oyster 14 x 17 x 5 flat closed	
BM-OTI141706FC	Oyster 14 x 17 x 6 flat closed	
BM-OTI141707FC	Oyster 14 x 17 x 7 flat closed	
BM-OTI141708FC	Oyster 14 x 17 x 8 flat closed	
BM-OTI141709FC	Oyster 14 x 17 x 9 flat closed	

System:
Oyster

Implant type:
ACIF

Typing:
flat closed

Material:
Ti6Al4VELI

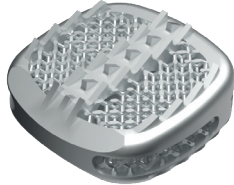
Article number	Description	Illustration
BM-OTI161704FC	Oyster 16 x 17 x 4 flat closed	
BM-OTI161705FC	Oyster 16 x 17 x 5 flat closed	
BM-OTI161706FC	Oyster 16 x 17 x 6 flat closed	
BM-OTI161707FC	Oyster 16 x 17 x 7 flat closed	
BM-OTI161708FC	Oyster 16 x 17 x 8 flat closed	
BM-OTI161709FC	Oyster 16 x 17 x 9 flat closed	

Oyster® ACIF Trial Implants

System:
Oyster

Implant type:
ACIF

Typing:
dome

Material:
Stainless Steel (17-4PH)

Article number	Description	Illustration
BM-OTR141504D	Oyster Trial sizer 14 x 15 x 4 dome	
BM-OTR141505D	Oyster Trial sizer 14 x 15 x 5 dome	
BM-OTR141506D	Oyster Trial sizer 14 x 15 x 6 dome	
BM-OTR141507D	Oyster Trial sizer 14 x 15 x 7 dome	
BM-OTR141508D	Oyster Trial sizer 14 x 15 x 8 dome	
BM-OTR141509D	Oyster Trial sizer 14 x 15 x 9 dome	

System:
Oyster

Implant type:
ACIF

Typing:
dome

Material:
Stainless Steel (17-4PH)

Article number	Description	Illustration
BM-OTR141704D	Oyster Trial sizer 14 x 17 x 4 dome	
BM-OTR141705D	Oyster Trial sizer 14 x 17 x 5 dome	
BM-OTR141706D	Oyster Trial sizer 14 x 17 x 6 dome	
BM-OTR141707D	Oyster Trial sizer 14 x 17 x 7 dome	
BM-OTR141708D	Oyster Trial sizer 14 x 17 x 8 dome	
BM-OTR141709D	Oyster Trial sizer 14 x 17 x 9 dome	

System:
Oyster

Implant type:
ACIF

Typing:
dome

Material:
Stainless Steel (17-4PH)

Article number	Description	Illustration
BM-OTR161704D	Oyster Trial sizer 16 x 17 x 4 dome	
BM-OTR161705D	Oyster Trial sizer 16 x 17 x 5 dome	
BM-OTR161706D	Oyster Trial sizer 16 x 17 x 6 dome	
BM-OTR161707D	Oyster Trial sizer 16 x 17 x 7 dome	
BM-OTR161708D	Oyster Trial sizer 16 x 17 x 8 dome	
BM-OTR161709D	Oyster Trial sizer 16 x 17 x 9 dome	

System:
Oyster

Implant type:
ACIF

Typing:
flat

Material:
Stainless Steel (17-4PH)

Article number	Description	Illustration
BM-OTR141504F	Oyster Trial sizer 14 x 15 x 4 flat	
BM-OTR141505F	Oyster Trial sizer 14 x 15 x 5 flat	
BM-OTR141506F	Oyster Trial sizer 14 x 15 x 6 flat	
BM-OTR141507F	Oyster Trial sizer 14 x 15 x 7 flat	
BM-OTR141508F	Oyster Trial sizer 14 x 15 x 8 flat	
BM-OTR141509F	Oyster Trial sizer 14 x 15 x 9 flat	

Oyster® ACIF Trial Implants

Article number	Description	Illustration
BM-OTR141704F	Oyster Trial sizer 14 x 17 x 4 flat	
BM-OTR141705F	Oyster Trial sizer 14 x 17 x 5 flat	
BM-OTR141706F	Oyster Trial sizer 14 x 17 x 6 flat	
BM-OTR141707F	Oyster Trial sizer 14 x 17 x 7 flat	
BM-OTR141708F	Oyster Trial sizer 14 x 17 x 8 flat	
BM-OTR141709F	Oyster Trial sizer 14 x 17 x 9 flat	

System:
Oyster

Implant type:
ACIF

Typing:
flat

Material:
Stainless Steel (17-4PH)

Article number	Description	Illustration
BM-OTR161704F	Oyster Trial sizer 16 x 17 x 4 flat	
BM-OTR161705F	Oyster Trial sizer 16 x 17 x 5 flat	
BM-OTR161706F	Oyster Trial sizer 16 x 17 x 6 flat	
BM-OTR161707F	Oyster Trial sizer 16 x 17 x 7 flat	
BM-OTR161708F	Oyster Trial sizer 16 x 17 x 8 flat	
BM-OTR161709F	Oyster Trial sizer 16 x 17 x 9 flat	

System:
Oyster





Implant type:
ACIF

Typing:
flat

Material:
Stainless Steel (17-4PH)

Oyster® Instruments

The product will be used in combination with the dedicated instrument set and standard spinal instruments (including caspar distractor and curettes).

Article number	Description	Illustration
BM-OINSS	Oyster Inserter with Stop	
BM-OINSTS	Oyster Inserter Tube with Stop	
BM-OINSP	Oyster Inserter Pin	
BM-OINS	Oyster Inserter without Stop	
BM-OINST	Oyster Inserter Tube without stop	



www.silony-medical.com

 **Silony Medical Europe GmbH**
An der Weide 27-29
28195 Bremen
Tel +49 421 24 69 56 0
Fax +49 421 24 69 56 55

 **BAAT Medical Products B.V.**
F. Hazemeijerstraat 800
7555 RJ Hengelo, The Netherlands
Tel +31 88 565 66 00

 0482