

(12) INTERNATIONAL APPLICATION PUBLISHED UNDER THE PATENT COOPERATION TREATY (PCT)

(19) World Intellectual Property  
Organization

International Bureau

(43) International Publication Date  
02 August 2018 (02.08.2018)



(10) International Publication Number  
**WO 2018/138307 A1**

(51) International Patent Classification:  
*A61B 17/64* (2006.01)

TR), OAPI (BF, BJ, CF, CG, CI, CM, GA, GN, GQ, GW,  
KM, ML, MR, NE, SN, TD, TG).

(21) International Application Number:  
PCT/EP2018/052058

Published:  
— with international search report (Art. 21(3))

(22) International Filing Date:  
29 January 2018 (29.01.2018)

(25) Filing Language: English

(26) Publication Language: English

(30) Priority Data:  
PCT/EP2017/051851  
27 January 2017 (27.01.2017) EP

(71) Applicant: UMC UTRECHT HOLDING B.V. [NL/NL];  
Yalelaan 40, 3584 CM UTRECHT (NL).

(72) Inventors: STRUIK, Thijmen; Yalelaan 40, 3584 CM  
UTRECHT (NL). LAFEBER, Floris Paulus Jacobus  
Gerardus; Yalelaan 40, 3584 CM UTRECHT (NL). LIN-  
DENHOVIUS, Karianne Hilde; Yalelaan 40, 3584 CM  
UTRECHT (NL). TER BRAAK, Hubertus Paul Maria;  
Yalelaan 40, 3584 CM UTRECHT (NL).

(74) Agent: LUTEN, Martin Haaije; Bezuidenhoutseweg 57,  
2594 AC Den Haag (NL).

(81) Designated States (unless otherwise indicated, for every  
kind of national protection available): AE, AG, AL, AM,  
AO, AT, AU, AZ, BA, BB, BG, BH, BN, BR, BW, BY, BZ,  
CA, CH, CL, CN, CO, CR, CU, CZ, DE, DJ, DK, DM, DO,  
DZ, EC, EE, EG, ES, FI, GB, GD, GE, GH, GM, GT, HN,  
HR, HU, ID, IL, IN, IR, IS, JO, JP, KE, KG, KH, KN, KP,  
KR, KW, KZ, LA, LC, LK, LR, LS, LU, LY, MA, MD, ME,  
MG, MK, MN, MW, MX, MY, MZ, NA, NG, NI, NO, NZ,  
OM, PA, PE, PG, PH, PL, PT, QA, RO, RS, RU, RW, SA,  
SC, SD, SE, SG, SK, SL, SM, ST, SV, SY, TH, TJ, TM, TN,  
TR, TT, TZ, UA, UG, US, UZ, VC, VN, ZA, ZM, ZW.

(84) Designated States (unless otherwise indicated, for every  
kind of regional protection available): ARIPO (BW, GH,  
GM, KE, LR, LS, MW, MZ, NA, RW, SD, SL, ST, SZ, TZ,  
UG, ZM, ZW), Eurasian (AM, AZ, BY, KG, KZ, RU, TJ,  
TM), European (AL, AT, BE, BG, CH, CY, CZ, DE, DK,  
EE, ES, FI, FR, GB, GR, HR, HU, IE, IS, IT, LT, LU, LV,  
MC, MK, MT, NL, NO, PL, PT, RO, RS, SE, SI, SK, SM,

(54) Title: SYSTEM FOR CONNECTING A CONNECTION DEVICE TO A BONE

(57) Abstract: System for connecting a connection device to a bone with a bone pin, wherein the system comprises a connection device provided with an opening for receiving the bone pin, and wherein the system further comprises a locking device arranged to be received in the opening of the connection device and which is arranged to engage the bone pin for locking the bone pin with respect to the connection device, wherein the locking device is movable between a locked position, wherein the bone pin is locked with respect to the connection device, and an unlocked position wherein the bone pin is movable with respect the connection device, wherein the system further comprises a blocking mechanism for at least partially blocking the opening in the connection device upon removal of the bone pin from the opening.



WO 2018/138307 A1

## System for connecting a connection device to a bone

The present invention relates to a system for connecting a connection device to a bone.

5 The always growing need for healthcare is accompanied by an increasing need for resources. In order to maintain and improve the level of care, a more effective and efficient use of resources, including costs of care, is demanded. In this light, the reusability of medical devices needs consideration. Besides these aspects, the reusability of medical devices is of influence on the safety of devices and to safety issues concerning the application of those devices, known as quality control.

Different categories of medical devices require different approaches in quality control with respect to their use. A common measure for reducing the risk of failure and therewith posing risk to a patient, is found in the development of single-use or disposable medical devices. This measure is often seen as an obvious choice when high risk products are considered (e.g. needles, scalpel blades and syringes). In addition, the regulations for disposable devices are less demanding for developers of medical devices, since quality during use can be more easily ensured. In case of a clear need for a single-use product, it might be stated that a developer has to incorporate a technical solution for making a device a disposable device. Or the other way, the developer has to state that multiple use is not part of the intended use and will lead to off-label use without guarantee of quality after its first use.

On the other hand, the choice for a reusable system may have a beneficial influence on costs within healthcare as in general, reuse of devices can be less costly per procedure than using disposable devices, especially when measures are taken for extending the lifetime of a product. In the field of medical devices, mostly initiated by end-users and developers, the options for reuse of devices labeled as single-use devices is explored. A reduction in e.g. costs of a procedure may for specific categories of devices be reduced without introducing additional risks for a patient.

30 For many medical devices or attributes however, the need for single-use does not easily become clear from its intended use, particularly for the end-user. Devices that are generally accepted to pose a low risk in case of reuse or failure, are easily overlooked. In these cases such devices may be reused without quality control, which results in use beyond the intended use. The lack of functional limitations of a medical device after use, allows for reuse of a device by the end user. Limiting measures, including the implementation of (partial) disposable components and visual

markings may improve the quality of care by introducing proper conditions for quality control of medical devices that can be reused but need quality control to prevent off-lable use.

It is a goal of the present invention, next to other goals, to provide a cost effective, easy to use,  
5 reliable and/or safe system for connecting a connection device to a bone with a bone pin wherein at least one of the above mentioned problems is at least partially solved.

This goal, amongst other goals, is met by a method according to appended claim 1.

10 According to the invention a system for connecting a connection device to a bone with a bone pin is provided, wherein the system comprises a connection device provided with an opening for receiving the bone pin, and wherein the system further comprises a locking device arranged to be received in the opening of the connection device and which is arranged to engage the bone pin for locking the bone pin with respect to the connection device, wherein the locking device is movable  
15 between a locked position, wherein the bone pin is locked with respect to the connection device, and an unlocked position wherein the bone pin is movable with respect to the connection device.

Such a device is for instance known from the copending international patent application with application number PCT/EP2015/067547, the contents of which are hereby incorporated by  
20 reference. In the above described system, a bone pin, or similar fixation element such as a bone wire, can be connected to a connection device, typically in the form of a connection block, provided with an opening extending between an upper and a lower surface of said connection device. When the connection device, which may be part of an orthopaedic device, is correctly placed with respect to the patient and the bone pin, a locking device may be used to interlock the  
25 pin to the connection device. The locking device is hereto movable from an unlocked position, in which the bone pin is movable, in particular slidable, with respect to the connection device, and a locked position, wherein the bone pin is locked with respect to the connection device.

Preferably, the locking device has an inner diameter substantially corresponding to the diameter of  
30 the bone pin. According to a preferred embodiment, the locking device has an annular body having an outer diameter corresponding to the diameter of the opening of the connection device and an inner diameter suitable for engaging and locking the bone pin. The outer surface having the outer diameter is then arranged to efficiently connect to the connection device due to the matching diameters. A suitable interconnection between the locking device and the connection device is  
35 obtained if the connecting device and the locking device are provided with cooperating interconnecting means, for instance in the form of threading. As an alternative, or in addition

thereto, it may however also be possible that the locking device and the connection device interconnect at another location than the outer surface of the locking device.

The inner surface of the locking device is then preferably arranged to be able to lock the bone pin by engagement in the locked position. This prevents movement between the locking device and the bone pin, such that also relative moment of the bone pin with respect to the connection device is prevented.

It is preferred that the locking device is movable from the locked position to the unlocked position.

This allows a practitioner to adjust the relative position of the connection device and the bone pin or for removal of the connection device from the bone pin. To however prevent reuse of the connection device, in particular upon removal of the bone pin from the locking device, the system according to the invention comprises a blocking mechanism for at least partially blocking the opening in the connection device, preferably after removal of a bone pin from the opening of the connection device. This prevents, or at least makes it more difficult, to reuse the connection device with for instance another, or the same, patient. The blocking mechanism preferably blocks the opening such that the opening is made unsuitable for insertion of a component of the system, such as the locking element or a bone pin. The blocking mechanism may block the opening as formed in the connection device directly, or the blocking mechanism may block any opening, for instance an opening in the locking device for receiving therein the bone pin. Also here, reuse of the system is prevented as the opening in the connection device is blocked by blocking the opening in the locking device.

According to a preferred embodiment, the blocking mechanism comprises a movable member which is movable to a position within the opening for blocking said opening. Upon removal of the bone pin or any other suitable element from the system, a movable member, which was preferably held in an unblocked position keeping the opening free, moves into the opening, thereby blocking the opening such that reinsertion of a component, preferably a bone pin, is restricted. The movable member may for instance be biased into the blocked position and held by a component in the unblocked position. Upon removal of said component, the movable member moves towards the blocked position. The movable member may for instance comprise a member provided in the wall of the opening which is movable from a position at least flush with said wall (i.e. substantially not protruding from said wall) to a position extending or protruding from said wall for blocking the opening.

According to a further preferred embodiment according to the invention, the system, or the blocking mechanism comprises, a retaining mechanism arranged for preventing removal of said locking device from said opening, preferably when the locking device is moved from the locked to the unlocked position. The retaining mechanism thus prevents removal of the locking device from the opening of the connection device, thereby blocking the opening and making the system unsuitable for reuse. The locking device is preferably retained in the opening such that removal by hand is not possible. A suitable tool may thus be used. Preferably, as will be discussed in greater detail below, at least a part of the locking device is retained in the opening such that said part is completely received in said opening. This makes removal of the locking device, or the part thereof, by hand difficult, if not impossible.

A reliable connection between the locking device and the connection device, in particular the opening thereof, is obtained if the movable member is arranged to interlock the locking device and the connection device. The movable member for instance forms a bayonet lock between the locking device and the connection device. It is preferred if at least one of the locking device and the connection device is provided with a recess for receiving said movable member for retaining the locking device in the opening. In the blocked position, the movable member is received in the recess, thereby preventing or obstructing removal of the locking device.

According to a further preferred embodiment, the retaining mechanism is arranged to allow insertion of the locking device into the opening and to prevent subsequent removal of the locking device from said opening. Hereto, the movable member may be biased towards the blocking position. Upon initial insertion of the locking device in the opening, the movable member is preferably urged towards the unblocked position, for instance using suitable guiding surfaces, to allow initial introduction of the locking device in the opening. The movable member is then, preferably after further insertion into the opening, received in the recess, from which the movable member cannot be removed without substantial or specified force. It is then preferred if the opening of the connection device, the movable member and/or the locking device is provided with a tapering surface for urging the movable member towards an unblocked position upon initial insertion of the locking device into the opening for guiding the movable member into the recess.

The movable member may be formed as an integral part of the opening or the locking device. The movable member may for instance be formed from the same material as and integrally with the connection device or the locking device. As an alternative, the movable member may be formed from another material, but integrally or connected with the connection device or the locking device. One of the locking device or the opening of the connection device may be provided with

the movable member, wherein the other of the locking device or the opening of the connection device may be provided with the recess for receiving the movable member therein.

It is however preferred if, according to a further preferred embodiment, the movable member is formed as a separate part. This allows a better locking action as the material can be specifically chosen for this purpose. The movable member is preferably formed as a ring shaped member received in a groove formed in one of the opening or the locking device, wherein the ring shaped member is movable between a blocking position wherein the ring shaped member protrudes from said groove and an unblocked position wherein the ring shaped member does not protrude from said groove. In other words, in unblocked position, the ring shaped or annular shaped member is at least flush (at least does not substantially protrude) from the surface wherein the groove is formed. This surface may be the inner surface of the opening or the outer surface of the locking device. In this unblocked position, the locking device can be inserted into the opening.

In order to allow an efficient movement of the ring shaped member from the blocked to the unblocked position, for instance when initially inserting the locking device in the opening, according to further preferred embodiment, in the blocked position at least a part of the ring shaped member lies at a distance from the bottom of the groove. This part is thus movable towards the bottom, thereby allowing the part protruding from the open end of the groove to be received in the groove. Efficient locking is obtained when the part of member protruding from said groove lies at a distance from the bottom of the groove. This protruding part is then efficiently moved inwardly upon moving to the unblocking position.

To increase the blocking of the ring shaped member, the ring shaped member comprises two diametrically opposed parts protruding from the groove, or a plurality of preferably equidistant protruding parts. These engaging parts preferably have a substantially rectilinear shape at the inner diameter. This forms substantially rectilinear parts for engaging the locking device. Preferably, at the location of these engaging parts, the ring shaped member lies at a distance from the bottom of the groove as mentioned above. One surface, in particular the outer surface, lies at a distance of the bottom of the groove for providing movement space, while the opposite surface, for instance at the inner diameter, protrudes from the groove for forming the engaging parts.

The ring shaped member need not to be a closed, i.e. to form a full circular ring. It is possible that the ring shaped member has the form of a broken annulus, i.e. only a sector of a ring. The opening in the ring can then provide flexibility to the ring shaped member. Next to a circular shape, the ring shaped member may further have the shape of an ellipse, as seen in a plane perpendicular to the

longitudinal axis of the opening. The vertices on the mayor axis may engage the bottom of the groove, while the vertices on the minor axis may form the engaging parts.

To ensure proper alignment in the groove for correctly receiving the locking element in the opening, it is preferred if the surface adjacent the bottom of the groove comprises, preferably at least in the blocked position, at least three contact points at mutual distances, preferably substantially equal mutual distances, on a circle having a diameter corresponding to the diameter of the bottom surface of said groove. The contact points are chosen on the perimeter of a circumscribed circle such that the centre of the ring shaped member remains substantially at the same location, i.e. remain aligned in the opening, upon moving between the blocked and unblocked positions. More preferably, the ring shaped member is arranged such that during insertion of locking device in the connection device, the tapering surface of the locking device has two contact points with the movable member. More preferably, said contact points are arranged such that the distance between each of said protruding parts and the longitudinal central axis of the opening remains substantially equal.

The ring shaped member preferably has the shape of at least two-thirds of a full annulus. This provides flexibility, while a good alignment is obtained. The deformation of the ring shaped member may however also, or as alternative, originate from the elastic properties of the material used.

The dimensions of the ring shaped member, in terms of inner and outer diameter, preferably corresponds to the dimensions of the groove wherein the member is seated. The groove for instance has a diameter at the location of bottom and a diameter at the location of the open end of the groove. The inner and outer diameter of the ring shaped member is formed accordingly.

The movable member in the form of a ring shaped member may have a circular cross-section. The diameter, or generally the size, of the cross-section of the ring shaped member may be adapted to adjust spring constant of the ring shaped member. A larger diameter will for instance result in a higher retaining force.

According to a further preferred embodiment, the movable member has an asymmetrical cross-section, seen along the plane perpendicular to the longitudinal axis of the opening. This allows for retaining the locking device more efficiently. The movable member, for instance in the form of the ring shaped member as mentioned above, may be formed as a barb. The movable member then preferably has a barb shaped cross-section for retaining the locking device upon removal thereof.

The movable member may then facilitate passing of the locking device in a first direction, to which end the cross-section may be provided with a tapering guiding surface at a first side as mentioned above, whereas passing in the other direction is prevented, for instance by a retaining surface at the other side, both seen in cross-sectional view. Preferably, a lower surface of the cross-section, seen in an insertion direction of the locking device from the upper surface of the connection device towards the lower surface thereof, is substantially flat for forming said retaining surface. Upon removing the locking device, said device will abut the retaining surface, thereby preventing removal thereof. The cross-section may for instance be generally triangular, wherein a base of said triangle is facing towards the lower surface of the connection device.

It is further preferred if the groove with the ring shaped member is formed in the opening of the connection device, wherein the protruding parts of the ring shaped member are received in a correspondingly shaped groove in the locking device. The ring shaped member is then movable between a blocking position, wherein the inner diameter of the ring shaped member is smaller than the inner diameter of the opening of the connection device, and an unblocked position wherein the inner diameter of the ring shaped member is substantially equal to or smaller than the inner diameter of the opening.

As mentioned above, it is preferred if the connection device and the locking device can be interconnecting using threading as an example of interconnecting means. The retaining mechanism is preferably arranged to operate separately from the interconnecting means. In other words, although the interconnecting means, for instance in the form of threading, itself may retain the locking device into the opening in at least the locked position thereof, moving the locking device to the unlocked position, for instance rotating the locking device in said opening, will not prevent removal of the locking device from the opening. The retaining mechanism is thus arranged to operate separately from the interconnection means. The interconnecting means can thus be used to connect the locking device to the connection device, and can preferably be used to clamp the bone pin due to the moving engagement surfaces as mentioned above, while the retaining mechanism retains the locking device in the opening, in both the locked and the unlocked position of the locking device. More preferably, even if the interconnecting means are disengaged, the retaining mechanism retains the locking device in the opening. As an alternative, the retaining means may be arranged to maintain the interconnecting means in the engaged position.

In order to achieve an efficient locking of the bone pin, the locking device according to a preferred embodiment comprises an engaging surface for engaging the bone pin, wherein the engaging surface is movable towards and from said bone pin between the unlocked position, wherein the



bone pin is movable with respect to the engaging surface, and the locked position, wherein the engaging surface engages the bone pin for locking said bone pin with respect to the connection device by clamping. The engagement surface is preferably moveable radially inwardly towards the longitudinal axis of the bone pin.

5

The engaging surface may for instance be formed on movable or deformable parts of the locking device, such as tongues, which are movable towards and preferably also from the bone pin for locking the bone pin.

- 10 In order to be able to efficiently move the engaging surface to the locked position, the opening of the connection device preferably has a tapering diameter, seen along the longitudinal axis of the opening, for moving the engaging surface between the positions, upon longitudinal movement of the locking device with respect to the connection device. The tapering diameter, or at least varying diameter, of the opening then serves as a guiding surface for guiding the engagement surface
- 15 towards the bone pin for engagement. To further improve the movement of the engaging surface, the locking device preferably comprises a correspondingly shaped tapering outer diameter.

- As an alternative, it is also possible that only the locking device has a varying outer diameter, for instance a wedge shape, which urges the engaging surface onto the bone pin upon movement of the
- 20 locking device into the opening.

- The locking device may be formed as a single unit. This reduces the number of parts. It is however preferred that the locking device comprises an engaging element provided with at least one engaging surface and a separate driving element arranged to move the engaging element along the
- 25 longitudinal axis of the opening for moving the engaging surface from the unlocked to the locked position. Preferably, the driving element and the connection device are provided with cooperating connecting means. Although threading can be used here, it is preferred if a retaining mechanism similar as the mechanism discussed above is used.

- 30 When the engagement element is arranged to be moved to the locked position upon movement in the opening along the longitudinal axis as explained above, it is preferred that the engaging element comprises at least one second engaging surface at a distance from the first engaging surface, seen along the longitudinal axis of the opening. This allows clamping at two locations of the bone pin, thereby improving the locking action. The driving element is then preferably
- 35 provided with an opening for receiving the engaging element and wherein the opening of the driving element has a tapering diameter, seen along the longitudinal axis of the opening, for

moving the second engaging surface between the unlocked and locked position upon longitudinal movement of the driving element with respect to the engaging element. Also the engaging element and the driving element are then provided with cooperating guiding surfaces for urging the engaging surface towards the bone pin. As said, this improves the locking action.

5

It is also possible that the driving element and the engaging element are only provided with the second engaging surface as mentioned above such that the engaging surface of the engaging member is moved towards the bone pin upon moving the driving element longitudinally with respect to the engaging element as explained. The opening of the connection device then not needs to be tapered. Movement of the engaging surface of the engaging element is then induced by relative movement between the driving element and the engaging element. The engaging element and the driving element may thereto be provided with cooperating guiding surfaces, for instance surfaces tapering along the longitudinal direction.

10

According to a further preferred embodiment wherein the retaining mechanism is arranged to retain the engaging element of the locking device in the opening after removal of the driving element. The engaging element then blocks the opening as explained above. Preferably, the engaging element is completely retaining the opening. The length of the engaging element is thus preferably smaller than the length of the opening. This makes it difficult, if not impossible, to remove the engaging element from the opening without proper tools.

20

This is in particular advantageous when the movement of the engaging surface of the engaging element is induced by relative movement between the driving element and the engaging element. Removal of the driving element will then result in unlocking of the bone by disengagement of the engaging surface. Upon removal or loosening of the driving element (which may thereto be provided with threading cooperating with threading in the opening), the pin can be removed. The engaging element however remains in the opening.

25

A system according to a further preferred embodiment further comprises a second retaining mechanism for retaining the engaging element and the driving element, wherein the retention force of the retaining mechanism between the engaging element is larger than the retention force of the retaining mechanism between the engaging element and the driving element. Upon removal of the driving element, the driving element will come loose from the engaging element, instead of the engaging element coming loose from the connection device. The engaging device will thus be retained.

35

An efficient system is then obtained if both retaining mechanisms are provided with a ring shaped member as mentioned above, wherein the spring constants of said ring shaped members are different. As mentioned above, this can be obtained if the diameter of the ring shaped element of the second retaining mechanism is larger than the diameter of the retaining mechanism between the  
5 engaging element and the driving element.

According to a further preferred embodiment, the locking device in the form of the engaging element and the driving element are supplied in a connected configuration. The driving element and the engaging element can then be advanced over the pin together. Tightening of the driving  
10 element (for instance by relatively moving the engaging element and the driving element) will then result in locking of the bone pin. Upon removal, the engaging element remains in the connection device due to the weaker interconnection between the driving element and the engaging element than the interconnection between the engaging element and the connection device.

15 A further preferred embodiment of the invention further comprises a guiding tube arranged to guide the bone pin from the connection device to the bone for connecting the bone pin to the bone, wherein the inner diameter of the guiding tube corresponds to the outer diameter of the bone pin and wherein the guiding tube can be slidably received in the opening, the guiding tube being  
20 slidable with respect to the connection device along an axis parallel to a longitudinal axis of the opening. Inserting the bone pins by drilling needs protection of the soft tissues during drilling by a guiding tube, sometimes also referred to as a cannula or sleeve, around the bone pin protecting soft tissue to be harmed by the rotating bone pin during drilling. To enable drilling of a bone pin through the connection device using the guiding tube and subsequent fixation of the bone pin after  
25 removal of the guiding tube to the connection device, a locking device is provided. In a preferred embodiment, rotation of the guiding tube is blocked during drilling.

The opening is arranged to slidably receive a guiding tube. This allows adjusting the relative position of the guiding tube to be adjusted with respect to the connection device. It is in particular preferred that the depth of the guiding tube in the patient can be adjusted, such that the guiding  
30 tube is adjusted such that the distal end of the guiding tube abuts the bone. This prevents damage to the tissue surrounding the bone upon drilling of the bone pin. Preferably, the guiding tube is only movable along the longitudinal axis of the opening.

According to a further preferred embodiment, the outer diameter of the guiding tube is larger than  
35 the inner diameter of the locking device or the locking element thereof. This means that if the locking device is retained in the opening, a guiding tube cannot be received in the opening of the

connection device. The opening is thus blocked and this prevents reuse of the guiding tube and therewith of the system. .

It is hereby preferred if the guiding tube is movable with respect to the connection device and bone pin such that the guiding tube is removable from the combination of the bone pin and the connection device and wherein the locking device is arranged to lock the bone pin after removal of the guiding tube. The locking device is only inserted after insertion of the pin into the bone and after removal of the guiding tube. The connection device can thus efficiently be moved over the pin.

Upon inserting the locking device in the opening, i.e. sliding the locking device over the pin, the retaining mechanism, for instance the movable member thereof, is moved from the blocked position to the unblocked position to allow the initial insertion of the locking device, to subsequently lock the locking device to the connecting device to prevent removal of said locking device from said opening, for instance when the locking device is later moved from the locked to the unlocked position. As mentioned above, the system may thereto comprise a suitable tapering surface for urging the movable member backwardly allowing the locking device to pass, to subsequently lock the locking device into the opening upon receipt of the movable member in the recess.

As said, the locking device preferably has an inner diameter substantially corresponding to the diameter of the bone pin. In this embodiment, the locking device can only be placed in the opening after the removal of the guiding tube, as the guiding tube would not fit in the locking device. Providing a locking device having an inner diameter corresponding to the outer diameter of the bone pin allows a good locking action, as for instance the engagement surface only needs to be displaced over a little distance to obtain a good clamping action.

As an alternative, the locking device has an inner diameter substantially corresponding to the outer diameter of the guiding tube in the unlocked position. This allows the locking device to be already in place in the opening when the guiding tube is guided in the opening. The locking device may then have a guiding function for guiding the guiding tube. When the guiding tube is removed after insertion of the pin in the bone, the engagement surface is moved towards the bone pin, thereby bridging the wall thickness of the then removed guiding tube, to clamp the bone pin.

According to a further preferred embodiment, the connecting device and/or the locking device (the driving element and/or the locking element) is made from a metal or a plastic. Suitable materials include aluminium, stainless steel, composites and polymers.

- 5 The present invention is further illustrated by the following Detailed Description and Figures, which show a preferred embodiment of the device and method according to the invention, and are not intended to limit the scope of the invention in any way, wherein:
- 10 - Figures 1a-d schematically show a system and method for connecting a connection device to a bone;
  - Figures 2a-d schematically show a variant of the system of figure 1;
  - Figures 3a and b schematically show a variant of fixing a bone pin to a connection device;
  - Figures 4a-d schematically shows a further variant of fixing a bone pin to a connection device;
  - 15 - Figures 5a and b schematically show an engagement element of the locking device in front view and cross section;
  - Figures 6a-f show alternatives of spring members, both in blocking and unblocking positions;
  - Figure 7 schematically shows an orthopaedic device using the system according to the invention;
  - 20 - Figure 8 shows a cross-section of the groove in an opening of the connection device with a ring shaped spring; and
  - Figures 9a-f show different cross-sectional shapes of the ring shaped spring.

25 The proposed system and method for application thereof relates to the assembly of a medical device, in particular a medical device for connecting a system to one or more bony structures, such that external loads applied to those bony structures are at least partially transferred via that system. Such systems include devices for medical procedures in traumatology and orthopedics such as bone lengthening, deformity correction, stabilization of complex fractures, joint fusion and joint  
30 distraction by means of external fixation. Such a system may for instance be used to connect an external fixator to the bones of the upper and the lower leg, known as the femur and tibia.

External fixation procedures are characterized by the fixation elements that connect the bony structures to the system of choice. The majority of the applied fixation elements consists of either  
35 metal wires that penetrate a bone and provide structural stiffness after tensioning, also known as

Kirschner-wires, or consist of pins that can be screwed into the bone, sometimes requiring pre-drilling and tapping of the bony structure for optimizing the fixation capacity, also known as bone pins. An advantage of bone pins over wires is that the pins can be embodied as half pins, which only require an insertion site, although trans-fixating pins that fully penetrate a bony structure are also common. In general, multiple fixation elements for each bony structure are required for establishing a proper fixation between the bony structures and the system. In the following, the fixation elements, for instance in the form of wires and bone (half) pins as mentioned above, will also be referred to simply as bone pins.

10 In order to penetrate the bony structures, soft tissues such as skin and muscles that surround those structures need to be penetrated first. The insertion site of a wire or pin therefore needs to be considered carefully in determining a suitable location, such that risks of undesirable damage during fixation are minimized. Damage to other structures than skin and muscle tissues, such as nerves, veins and arteries, needs to be prevented. The system of choice should ideally provide  
15 sufficient range of motion such that an optimal fixation location can be chosen which does not compromise the surrounding soft tissues.

Furthermore, during penetration of the soft tissues with a fixation element in order to reach the bony structure, instruments, for instance guiding tubes, may be utilized for guidance of the fixation  
20 element while fixating it to the bony structure. Those instruments also serve as a barrier between the fixation element and the soft tissues during application and are known as sleeves or cannulas, protecting these soft tissues including neurovascular tissues from being damaged during fixation of the fixation elements, e.g. bone pins or wires, in or through the bone.

25 Once a fixation element is connected to a bony structure, a subsequent action comprises the fixation of the fixation element to the system, in particular a connection device, typically in the form of a connection block. In commonly applied embodiments of external fixation systems, the instruments as described for guidance can be separately applied from the other components of a fixation system, such that the instruments are not integrated with that system when in use. In case  
30 instruments for guidance during fixation are integrated with the connection system, the risk of procedural errors may be reduced since the order of actions can be dictated by the components of that system. This may result in fewer actions during use of the system, in quicker surgical procedures, and a reduction in therewith associated risks and costs. As such, an system that has integrated instruments for guidance may attribute to an improvement of therapy and care.

35 In addition, a system having integrated instruments may attribute to user-related aspects regarding ease of use, by reducing the total number of actions while using the system, specifically by

reducing the number of user-related errors such as repetitive actions and the number of incorrect actions.

The safe use of external fixation systems furthermore relies on correct functioning of the device.

5 Due to the repetitive use of systems, the performance may be compromised. Due to the lack of quality control on critical aspects for correct functioning of reusable connection systems, inferior performance of a system may occur, introducing the risk of system failure. Common failures comprise fatigue and wear of components. Ideally, quality control should test critical aspects of systems after application during a surgical procedure, and affected parts or systems should be  
10 replaced in case inferiority is confirmed.

A reusable system which requires quality control and revision after every performed surgical procedure might combine the cost benefits of reusability of a system and the benefits of quality control that disposable systems have. Such a system might comprise of a system that requires  
15 multiple subsequent actions during the surgical procedure that established fixation of the system to the bony structures, wherein performing one or more essential actions within this cascade, e.g. the insertion of a locking element for locking a fixation element in a system, can only be performed once, as such that action is an irreversible action. From this approach, the option of reversing the procedure passes. The corresponding risks should be evaluated in the choice of irreversible actions  
20 of the surgical procedure. Typically, the subsequent actions required for connecting a connection device to a bony structure with a self-drilling and self-tapping bone pin comprise of:

- the making of a surgical incision at the anatomical position of choice;
- the spreading of the soft tissues up to the bony structure;
- the insertion of a sleeve (guiding tube), in the direction of choice and at the chosen  
25 anatomical position;
- application of the bone pin to the bone structure through the sleeve (protecting neurovascular and soft tissues from damage during drilling);
- removal of the guiding sleeve;
- positioning of the connection device;
- 30 - fixation of the connection device to the bone pin;

#### The driving element and the locking element

In a final action of a surgical procedure, the fixation between the connection device and the fixation element is established. The present invention relates to the locking element within the  
35 system that receives and locks or holds the fixation element in the system, referred to as the locking action. The locking action establishes the connection between the fixation element and the

locking element by radial deformation of the fixation element along its longitudinal axis, such that the outer diameter of the fixation element corresponds to the inner diameter of the deformed locking element. The deformation is established by application of compressive loads that are preferably applied in the longitudinal axis of the fixation element, which equals the longitudinal axis of the locking element, and which is transferred into radial compressive loads.

The radial narrowing of the locking element is preferably caused by elastic deformation of the locking element, such that the geometry of the locking element is not compromised after the locking action is resolved, such that the locking element can be reused. For several reasons, including quality control, it may however be preferred to plastically deform the locking element during the locking action.

In a preferred embodiment, the compressive loads are applied to the locking element via a driving element, applied in the longitudinal axis of the locking element and the fixation element, the driving element enclosing the locking element in the connection element of the connecting device. The geometrical properties of the connection device, the locking element, and the driving element furthermore correspond such that an axial enclosure of the locking element yields to radial compression of the locking element.

In a preferred embodiment, the locking of a fixation element, e.g. a bone pin, in the connection device is established by means of a subassembly consisting of a driving element and a locking element, together also referred to as the locking device. The driving element and the locking element are preferably joined by an enclosing geometry of the driving element for enclosing the geometry of the locking element. The enclosing characteristics may require a temporary, preferably elastic, deformation for establishing the enclosure of the locking element in the driving element, such that the subassembly can be handled as a single part during the procedure known as the surgical procedure.

During the action described as the irreversible action, the driving element may be connected to the locking element using a retaining element. The retaining element may interconnect the locking and the driving element. Previous to this action, the retaining element, the locking element and the driving element may be assembled to a subassembly.

For connecting the assembly as mentioned above, or locking device, to the connection device, a further and preferably separate retaining mechanism is provided. The retaining mechanism retains



the locking device, or at least a part thereof, in the connection device. The retaining mechanism may again comprise a separate, second retaining element.

- 5 In the action that causes the fixation of the driving element in the locking element, preferably by means of application of a predetermined torsional load that causes compressive loads in the longitudinal axis of the components, deformation of the locking element is established such that the applied load is converted to a compressive load on the bone pin and fixation of the bone pin within in the connection element yields.
- 10 The loads that are required for establishing the subassembly (the locking device) consisting of the locking element and the driving element are furthermore lower than the loads required for removing the locking device from the connection device. The retaining mechanism thus requires more force to disassemble than the retaining element between the locking element and the driving element. The retaining mechanism may function by deformation of the locking element. The driving element is thus removed when pulling out the driving element, while the locking element is retained. As such, the irreversible action can be performed without locking the fixation element. In addition, the locking action can be reversed within the surgical procedure while the irreversible action is irreversible during the surgical procedure.
- 15
- 20 Dissolving the fixation of the bone pin is achieved by loosening the driving element from the locking element, such that the compressive load on the bone pin is reduced and the clamping force between the locking element and the bone pin is dissolved. This property is considered important for adaptation of the relative position of the connection element to the axial direction (longitudinal) of the bone-pin in case of clinically necessity. Under these conditions the locking element is still
- 25 irreversibly retained in the connection device.

The assembly of the driving element, the locking element, the retaining element, and the bone pin may have the property that the connection between the driving element and the locking element requires less external load for disassembling the subassembly of the driving element and the locking element into separate parts than for the assembly that originates from the irreversible

30 action that encloses the locking element in the connection device. As such, the driving element may be separated from the locking element, while the locking element remains retained in the connection device.

35 A repetition of the cascade of actions required for fixating the connection device to the bone pin is obstructed by the locking element that is situated within the connection element after the driving

element is removed in the process of removing the connection device after a therapy has ended, by obstructing the channel in the connection block that is required for inserting the guiding cannula or sleeve. Removal of the locking element from the connection element allows for performing common actions required for reuse of external device viz. the medical products, including cleaning, quality control, revision, packaging, and sterilization.

In a preferred embodiment, the enclosing geometry of the driving element is established by means of a the retaining element as an additional part assembled to the driving element, allowing for the deformation required for establishing the enclosure of the locking element in the driving element. Such a part may be designed as a ring or slot ring which allows for sufficient elastic deformation such that the ring can be received in a corresponding opening in the driving element, and such that the part holds the locking element retained within the driving element. Also the second retaining element, interconnecting the locking element and the connection device, may have a similar structure, although this part is preferably arranged to exert a higher retaining force than the other retaining element (interconnecting the driving element and the locking element) such the assembly of the locking element and the driving element will disengage, leaving the locking element in the opening connection device.

Although such an embodiment allows for having one or both of the parts as either a disposable or reusable part, it is especially preferred in the specific case that reuse of the system as a whole, including the locking element, is intended, based on the characteristic that the connections between the locking element and the other parts of the system may be reversed without compromising the locking element.

In another preferred embodiment, the functional characteristics of the driving element and the locking element are combined in the same part, said part having the ability of allowing separation of its characteristics into at least one part being a separate driving element and one part being a separate locking device during the action that is described as the irreversible action. The embodiment may consist of multiple parts that are assembled by means of an irreversible method, including the methods of welding, soldering, gluing, screwing, press fitting, and riveting. Such an embodiment is especially preferred in the specific case that the quality control of the system is ensured by having a partially disposable system, the driving element and the locking element being the disposable parts of that system. For such a system, it is furthermore preferred to establish a connection between the connection element and the locking element, such that the system requires a specific action of removal of the disposable locking element from the connection element in order to use the system as a reusable system.

Detailed description of the figures

In figures 1a-d the steps for connecting a connection device 1 in the form of a connection block to a bone 100 is shown. The connection block 1 is thereto provided with an opening 11 which extends  
5 between a first surface 12, which faces the patient 101, and a second surface 13 which faces away from the patient 101. The opening 11 has a section 11a towards the second surface 13 which is provided with threading 14. Towards the patient facing surface 12, the opening 11 is provided with a tapering section 11b wherein the diameter of the opening 11 becomes smaller in the direction of  
10 the patient 101, seen along a longitudinal axis A of the opening 11.

Inserted into the opening is a locking device 2 which has a substantially annular shape and is shaped to fit inside the opening 11. The locking device 2 has a flange 21 at one side and deformable tongues 22 at the other side and a body 23 provided there between. The body 23 is  
15 provided with threading 24 for cooperation with the threading 14 of the opening. The outer diameter of the body 23 of the locking device 2 thereby corresponds to the diameter of the first section 11a of the opening 11. The length of the body 23 provided with the threading 24 preferably corresponds to the length of the first section 11a of the opening 11, seen along the longitudinal axis  
A.

20

The threading 14, 24 fixes the relative position of the locking device 2 and the connection device 1, which position can be adjusted by rotating the locking device 2. In the position as shown in figure 1a, the lower surface of the flange 21 extends at a distance from the surface 13, such that further movement of the locking device 2 in a direction indicated with I in figure 1a is possible, as will be  
25 explained in greater detail below. In the situation as shown in figure 1a, the tongues 22 of the locking device 2 only partially extend in the tapering section 11b of the opening 11.

The inner diameter of the locking device 2, including the diameter at the location of the tongues 22, corresponds to the outer diameter  $d_1$  of a guiding cannula 3. This limits relative movement of  
30 the locking device 2, which also serves as a guiding device for guiding the cannula 3, in a direction along the longitudinal axis A. The guiding cannula 3 is arranged to guide a bone pin 4 from the connection device 1 to the bone 100, see figure 1b. In inserted situation as shown in figure 1b, the cannula 3 is thereto slidable along the longitudinal axis A with respect to the locking device 2 and thereby with respect to the connection device 2. A flange 32 is provided to allow efficient  
35 adjustment of the depth of the cannula 3. This allows efficiently guiding a bone pin 4 to the bone 100, irrespective of the distance between the connection device 1 and the bone 100. When the

cannula 3 is advanced sufficiently far such that a distal end 31 abuts the bone 100, the bone pin 4 can be inserted into the cannula 3, schematically indicated with the arrow in figure 1b. The inner diameter of the cannula 3 thereto corresponds to the outer diameter of the bone pin 4 such that relative movement of the bone pin 4 in the cannula 3 is again restricted to movement along the longitudinal axis A. The movement of the bone pin 4 with respect to the connection device 1 is therefore also fixed.

In a next step, see figure 1c, the bone pin 4 can be fixed to the bone 100. In this example, self-tapping bone screws 4 are used, such that the bone pins 4 are inserted into the bone 100 by rotating the bone pin 4 inside the cannula 3. The cannula 3 thereby prevents damage to the surrounding tissue of the patient 3. Other bone pins 4 can however be used.

After fixation of the bone pin 4 to the bone 100, the cannula 3 can be withdrawn from the combination of the bone pin 4, the locking device 2 and the connection device 1. This movement is indicated with the arrow in figure 1c. As the inner diameter of the locking device 2 corresponds to the outer diameter of the cannula 3, which is larger than the outer diameter of the bone pin 4, the bone pin 4 is held in the locking device 2 with play. Therefore, in order to lock the bone pin 4 with respect to the locking device 2 and thereby with respect to the connection device 1, the locking device 2 is rotated, thereby moving the locking device 2 along the longitudinal axis A, see arrow in figure 1d, in the opening 11. The outer surfaces of the tongues 22 will thereby engage the inner surface of the tapering section 11b, urging the tongues 22 radially inwardly, i.e. towards the longitudinal axis and thereby towards the bone pin 4. The inner surface of the deformable tongues 22 thereby act as engaging surfaces which are arranged to engage the bone pin 4, thereby locking the bone pin 4 with respect to the locking device 2 and thereby the connection device 1. In the locked position as shown in figure 1d, the lower surface of the flange 21 of the locking device 2 abuts the upper surface 13 of the connection device 1, which is in this example provided with a correspondingly shaped recess to receive the flange 21 in a countersunk manner.

In this situation, the bone pin 4 is firmly locked with respect to the connection device 1. It will be appreciated, as will be explained in greater detail below, that the bone pin 4 can simply be unlocked by rotating the locking device 2, thereby loosening the tongues 22 such that the locking device 2 is again movable with respect to the bone pin 4.

To however prevent that the locking device 2 is removable from the connection block 1, the system is provided with a retaining mechanism for retaining the locking device 2 in the opening 11 of the connection block 1. The retaining mechanism is exemplary formed by a protrusion 22a on the

tongue 22 which engaged in a correspondingly shaped recess 11c in the opening 1. When locking the locking device 2, when moving from figure 1c to 1d, the protrusion 22a snaps into the recess 11c. The recess 11c may have a length in longitudinal direction which is longer than the length of the recess to allow some longitudinal movement of the locking device 2 with respect to the connection block 1. The locking device 2 can thus be unlocked, while the retaining mechanism prevents that the locking device 2 can be removed from the connection block by hand.

In the example shown in figures 1a-d, the locking device 2 serves to lock the bone pin 4 and to guide the cannula 3. It is however also possible to use a separate guiding device to guide the cannula 3. Moreover, in the above example, the relative position of the locking device 2 and the connection device 1 is fixed using threading 14, 24. Other means can however be used as will also be shown with reference to figures 2a-d

The connection device 1 as shown in figures 2a-d is similar to the connection device 1 as shown in figures 1a-d and is again provided with an opening 11. The diameter of this opening 11 is again larger than the outer diameter  $d_1$  of the cannula 3, such that a guiding device 5 is used to limit the relative movement between the cannula 3 and the connection device 1 along the longitudinal axis A, see figure 2b. The guiding device 5 again has an annular shape and has an inner diameter corresponding to the outer diameter  $d_1$  of the cannula 3. This allows efficient adjustment of the depth of the cannula 3 with respect to the connection device 1 as indicated with double arrow in figure 1b. Note that this is different from the locking device 2 as used in figures 1a-d.

Instead of threading, the guiding device 5 is provided with a deformable part 51 which locks into the opening 11 upon inserting the part 51. The deformable part 51 thereby exerts a clamping action of the inner surface of the opening 11, thereby retaining the guiding device 5 in the opening 11 by friction. The guiding device 5 is further provided with a flange 52 for easy manipulation of the guiding device 5.

After insertion of the bone pin 4, see figure 2c, the combination of the guiding device 5 and the cannula 3 can be removed from the combination of the bone pin 4 and the connection device 1, see arrow figure 2d. As the bone pin 4 is firmly attached to the bone, the combination can be withdrawn by pulling sufficiently hard to overcome the friction of the deformable part 51 of the guiding device 5 or by rotating the guiding device in case of a threaded connection between the guiding device and the connection device. The cannula 3 and the guiding device 5 can hereby be removed in unison.

Although a locking device similar to the locking device as shown in figures 1a-d can be used to lock the bone pin 4 with respect to the connection device 1, for instance by providing corresponding threading, it is also possible to use a locking mechanism formed of two separate parts, as is shown in figures 3a and 3b.

5

The locking mechanism comprises a driving element 6 and a locking element 7, wherein the annularly shaped locking element 7 is provided with sets of tongues 71, 72 at either side. Both sets of tongues 71, 72 are arranged to move radially inwardly upon deformation, thereby locking the bone pin 4. As an alternative, only one set of tongues may be provided, for instance the upper ones 72. The first set of tongues 71 at the lower side of the locking element 7 are moved radially inwardly upon moving, or driving, the locking element 7 in a direction indicated with the arrow in figure 1a. The reduction of the diameter indicated with 19 in the opening 11 will thereby urge the tongues 71 towards the outer surface of the bone pin 4. A groove 11c, similar to the groove in figures 1a-d, is provided near end of the opening 11 towards the patient, wherein ribs 71a of the tongues 71 can snap for locking the relative positions of the locking element 7 with respect to the connection device 1. The ribs 71a form a retaining mechanism for retaining the locking element 7 in the opening 11. In this locked position, the tongues 71 exert a firm clamping action on the bone pin 4 at a location along the longitudinal axis A indicated with the arrow C in figure 3b, thereby preventing movement of the bone pin 4.

20

To further improve the locking action, also or only the tongues 72 provided on the upper side of the locking element 7 will be urged radially inwardly upon movement of the driving element 6 towards the locking element 7. More specifically, the annularly shaped driving element 6 is provided with an opening 61 of which the lower section 64 has a tapering diameter, wherein the diameter increases towards the lower side. The tapering section 64 forms a guiding surface for urging the tongues 72 inwardly, i.e. towards the bone pin 4, when the driving element 6 is moved towards the locking element 7.

25

Also the tongues 72 can be provided with ribs 72a as second retaining mechanism which can be received in a correspondingly shaped groove 63 at the end of the guiding surface. This connects the driving element 6 to the locking element 7 and thereby to the connecting device 1. In the situation as show in figure 3b, the tongues 72 exert a clamping action on the bone pin 4 at a location along the longitudinal axis A indicated with B, at a distance from location C. This improves the locking action of the locking mechanism.

35

The retaining mechanism C retaining the locking element 7 in the opening 11 of the connection block 1 exerts a larger retaining force than the retaining mechanism B retaining the locking element 7 to the driving element 6. If the driving element 6 is thus removed, for instance by rotating against the threading, the driving element 6 will become loose from the locking element 7 before the locking element 7 becomes loose from the connection block 1. The locking element 7 will thus remain in the opening 11. As the length L1 (corresponding to the height of the connection block 1) is larger than the length L2 of the locking element 7 and the locking element 7 is completely contained in the opening 11, it is difficult, if not impossible, to remove the locking element 7 from the connection block 1 by hand, instead requiring a dedicated tool or toolset for removal. As the inner diameter of the locking element 7 is smaller than the outer diameter of a guide 3 (see figures 2a-d, the system with the retaining locking element 7 can not receive another guide 3, such that the system is not reusable up till removal of the locking element from the connection block.

15 Instead of ribs 71a, 72a, other movable members may be used to retain the elements together. An example of other movable members in another embodiment is shown in figures 4a-c. The step as shown in figure 4a may follow the step as depicted in 2d with similar parts.

In figures 4a-d a connection block 1 similar to the block 1 of figures 2a-d is shown. The opening 11 is at an upper part again provided with threading 14 for interconnecting a driving element 6 which is provided with cooperating threading 64. A lower part of the opening 11 is again provided with a recess 11c in which in this embodiment a ring shaped spring 8 is arranged. The ring shaped spring 8 is a movable member which is movable with respect to the inner surface of the opening 11 and is biased to protrude from said surface.

25

The configuration of the ring shaped spring 8 in the groove 11c according to a preferred embodiment is shown in figures 6a and 6b, which show the cross sections of the groove 11c in the connection block 1 as indicated with the set of arrows in figure 4a. Figure 8 shows a cross-section of the groove 11c in a plane perpendicular to the longitudinal axis A. The contour of the groove 11c is shown in dashed lines and indicates a bottom wall 111 of the groove and an open end 112 (indicated with dashed lines in figure 8). The open end 112 is flush with the inner surface 11e of the opening 11. Received in the groove is the ring shaped spring 8 which has the shape of a broken annulus, i.e. an annular sector two thirds of a complete, full annulus. The open part between the ends 83 of the spring 8 provides flexibility to the spring.

35

The outer and inner surfaces of the spring 8 substantially correspond to the inner diameter and outer diameter of the groove, i.e. of the open end 112 and the bottom 111. The spring 8 is provided with three contact points 81a-c which are provided on a circumscribing circle with the same diameter as the diameter of the bottom wall 111. The three contact points 81a-c are provided at substantially equal mutual distances  $d$  (indicated between 81a and 81b in figure 6a. This results in a centring of the spring with respect to the opening. When receiving the locking element, two surfaces of the ring shaped spring are in contact therewith.

Substantial rectilinear parts 84 are provided at diametrically opposite locations which protrude from the groove 11c in the blocking position as shown in figure 6a. The cross-section of figure 8 is taken at these parts 84. The inner surface 842 of the part 84 protrudes from the open end 112. The opposite surface 841 of the part 84 on the other hand lies at a distance from the bottom wall 111 (see the double arrow on the right of figure 8). When the spring 8 is urged to the unblocking position as shown in figure 6b, the parts 84 will move radially outwardly, accommodated by the space between the surface 841 and the wall 111 until the outer surfaces 842 are flush or even within the open end 112 of the groove 11c. The opening 11 is now unblocked. Due to the spring working of the spring 84, the spring will return to the position as shown in figure 6a once the geometry of the locking element 111 allows. In figures 6c-f, two alternative springs 8b, 8c are shown in blocked (6c, 6e) and unblocked (6d, 6f) positions. Also here, parts 84 of the spring can be moved within and without the inner surface (indicated with 111) of the opening 1

Figures 9a-f show different cross-sections of the spring 8, or more generally the movable member. Whereas the cross-section as shown in figure 9a has a symmetrical configuration with respect to a plane P (See figure 9b) perpendicular to the longitudinal axis A of the opening 11, the cross-sections as shown in figures 9b-9f have an asymmetrical shape with respect to this plane. These configurations have the advantage that a first side (at the top) forms a guiding surface which urges the spring 8 inwardly (to the left in the figures) when an element, such as the locking element, is inserted, which is indicated with the arrow in figure 9b. The cross-sections are however barb shaped, such that movement of such an element in the opposite direction, see the arrow in figure 9c, will not result in movement to the unblocked position. The lower surfaces preferably are substantially flat (figures 9b-9d) or define an engaging point onto which the element will abut when such an element would be removed from the opening 11.

Back to figures 4a-d, after insertion of the pin 4 in the bone, a combination of the driving element 6 and the locking element 7 is inserted into the opening. The combination has an annular shape and has an opening with a diameter corresponding to the diameter of the pin 4. In the opening 61 of the



driving element 6 is a groove 61c wherein a ring shaped spring 8b is held, similar to the spring 8 is the opening 11 of the connection block 1. The locking element 7 is provided with groove 71c (see also the cross section of figure 5b) wherein the spring 8b is received. A lower part of the locking element 7 is provided with a more longitudinally formed groove (seen along the axis A) for receiving the other spring 8, such that relative motion between the locking element and the connection block for unlocking the bone pin remains possible. The lower part of the locking device 7 has a tapering surface 71e (figure 5b).

Upon inserting (indicated with the arrow in figure 4a) the combination of the locking element 7 and the driving element 6, which together form a locking device 2 (see for instance figure 1) in the framework of the invention, the threading 64 of the driving element 6 will engage the threading 14 in the upper part 11a of the opening 11. Further movement, by rotating the driving element 6, may eventually result in the flange 73 (figure 5b) of the locking element 7 abutting the step between the wider upper part 11a and the narrower lower part 11b of the opening 11. Further rotation, thus further insertion of the driving element 6 in the opening 11 will now result in a relative movement between the driving element 6 and the locking element 7. As the driving element 6 and the locking element 7 are provided with cooperating tapered surfaces 72 64, this movement will result in the tongues 72 moving inwardly, see the front view of figure 5a. Generally speaking, relative movement of the driving part 6 with respect to the locking device 7 will lock the bone pin 4 in the locking element.

Upon further inserting the combination of the locking element 7 and the driving element 6, the tapered surfaces 71e will upon contacting the spring 8, which protrudes from the surface of the wall of the opening 111 (figure 6a), urge the spring backwardly (figure 6b). Further movement will result in the spring locking into the groove 71d, the spring restoring its shape to the initial shape (figure 6a). The locking element 7 is now locked in the connection block 1.

With reference to figure 4b, the system comprises two retaining mechanisms, the location of which are generally indicated with arrows B and C. The retaining force of the first retaining mechanism C, thus the friction between the connection block 1 and the locking element 7, is larger than the retaining force of the second retaining system B, the friction between the locking element 7 and the driving element 6. If the driving element 6 would thus be removed, it will separate from the locking element 7 before the locking element 7 will separate from the connection block 1. The locking element 7 is thus retaining in the connection element 1, thereby blocking the opening 11 for further insertion of a guiding tube 3. Upon removal of the driving element 7, the tongues 72

will move outwardly (figure 4c), which allows removal of the bone pin 4 (figure 4d). The locking element 7 is hereby completely contained in the opening.

5 In the above example, similar ring shaped spring elements 8, 8b are used. In order to obtain a larger friction force in the first retaining mechanism C, the diameter of the spring element 8 is larger than the diameter of the spring element 8b, thereby resulting in a higher spring constant. Differences in stiffness may however also result from differences in e.g. cross sectional geometry or material properties.

10 The connection system is particularly suitable to connect a connection device to a bone or bone fragment with two parallel bone pins. Such a system is in figure 7, using two connection block 1a, 1b with a correcting system 130 in between. Although in this figure a connection system is shown which corresponds to the system as shown in figures 1a-d, it will be appreciated that the same applies to the system as shown in figures 2-6, or combinations thereof.

15

The present invention is not limited to the embodiment shown, but extends also to other embodiments falling within the scope of the appended claims.

## Claims

1. System for connecting a connection device to a bone with a bone pin, wherein the system comprises a connection device provided with an opening for receiving the bone pin, and  
5 wherein the system further comprises a locking device arranged to be received in the opening of the connection device and which is arranged to engage the bone pin for locking the bone pin with respect to the connection device, wherein the locking device is movable between a locked position, wherein the bone pin is locked with respect to the connection device, and an unlocked position wherein the bone pin is movable with respect the  
10 connection device, **characterized in that** the system further comprises a blocking mechanism for at least partially blocking the opening in the connection device upon removal of the bone pin from the opening.
2. System according to claim 1, wherein the blocking mechanism comprises a movable  
15 member which is movable to a position within the opening for blocking said opening.
3. System according to claim 1 or 2, wherein the blocking mechanism comprises a retaining mechanism arranged for preventing removal of said locking device from said opening when the locking device is moved from the locked to the unlocked position.
- 20 4. System according to claims 2 and 3, wherein the movable member is arranged to interlock the locking device and the connection device.
5. System according to claim 4, wherein at least one of the locking device and the connection  
25 device is provided with a recess for receiving said movable member for retaining the locking device in the opening.
6. System according to claim 5, wherein the opening of the connection device, the movable  
30 member and/or the locking device is provided with a tapering surface for urging the movable member towards an unblocked position upon initial insertion of the locking device into the opening for guiding the movable member into a recess.
7. System according to claim 5 or 6, wherein the movable member is formed as a ring shaped  
35 member received in a groove formed in an opening of the locking device, wherein the ring shaped member is movable between a blocking position wherein the ring shaped member protrudes from said groove and an unblocked position wherein the ring shaped member does not protrude from said groove.

8. System according to claim 7, wherein in the blocked position at least a part of the ring shaped member lies at a distance from the bottom of the groove.
- 5 9. System according to claims 7 and 8, wherein the part of the ring shaped member which protrudes from said groove lies at a distance from the bottom of the groove.
10. System according to claim 7, 8 or 9, wherein the ring shaped member comprises at least two diametrically opposed parts protruding from the groove.
- 10 11. System according to any of the claims 7 - 10, wherein the surface adjacent to the bottom of the groove comprises at least three contact points at mutual distances on a circle having a diameter corresponding to the diameter of the bottom surface of said groove for aligning said ring shaped member in the opening of the connection device.
- 15 12. System according to at least claims 6 and 11, wherein during insertion of locking device in the connection device, the tapering surface of the locking device has two contact points with the movable member.
- 20 13. System according to any of the preceding claims 2 - 12, wherein the movable member has a barb shaped cross-section for retaining the locking device upon removal thereof.
14. System according to any of the preceding claims 3 - 13, wherein the connecting device and the locking device are provided with cooperating interconnecting means, for instance in the form of threading, wherein the retaining mechanism is arranged to operate separately from the interconnecting means.
- 25 14. System according to any of the preceding claims 3 - 13, wherein the connecting device and the locking device are provided with cooperating interconnecting means, for instance in the form of threading, wherein the retaining mechanism is arranged to operate separately from the interconnecting means.
- 30 15. System according to any of the preceding claims, wherein the locking device comprises an engaging surface for engaging the bone pin, wherein the engaging surface is movable towards and from said bone pin between an unlocked position, wherein the bone pin is movable with respect to the engaging surface, and a locking position, wherein the engaging surface engages the bone pin for locking said bone pin with respect to the connection device by clamping.
- 35 16. System according to claim 15, wherein the locking device comprises an engaging element provided with at least one engaging surface for engaging the bone pin for locking said pin and a separate driving element arranged to move the engaging element along the

longitudinal axis of the opening for moving the engaging surface from the unlocked to the locked position.

- 5 17. System according to claim 16, wherein the retaining mechanism is arranged to retain the engaging element of the locking device in the opening after removal of the driving element.
18. System according to claim 17, wherein the engaging element is completely retained in the opening.
- 10 19. System according to claim 17 or 18, further comprising a second retaining mechanism for retaining the engaging element and the driving element, wherein the retention force of the retaining mechanism between the engaging element is larger than the retention force of the retaining mechanism between the engaging element and the driving element.
- 15 20. System according to claim 19, wherein both retaining mechanisms are provided with a ring shaped member according to any of the claims 7 - 10, wherein the spring constants of said ring shaped members are different.
- 20 21. System according to claim 20, wherein the diameter of the ring shaped element of the second retaining mechanism is larger than the diameter of the retaining mechanism between the engaging element and the driving element.
- 25 22. System according to any of the claims 16 - 21, wherein the driving element and the connection device are provided with cooperating connecting means as defined in claim 14.
- 30 23. System according to any of the preceding claims, further comprising a guiding tube arranged to guide the bone pin from the connection device to the bone for connecting the bone pin to the bone, wherein the inner diameter of the guiding tube corresponds to the outer diameter of the bone pin and wherein the guiding tube can be slidably received in the opening, the guiding tube being slidable with respect to the connection device along an axis parallel to the longitudinal axis of the opening.
- 35 24. System according to claim 23, wherein the outer diameter of the guiding tube is larger than the inner diameter of the locking device.
25. System according to claim 23 or 24, wherein the guiding tube is movable with respect to the connection device and bone pin such that the guiding tube is removable from the

combination of the bone pin and the connection device and wherein the locking device is arranged to lock the bone pin after removal of the guiding tube.

26. System according to any of the preceding claims, wherein the connecting device and/or the locking device is made from a metal or a plastic.
- 5



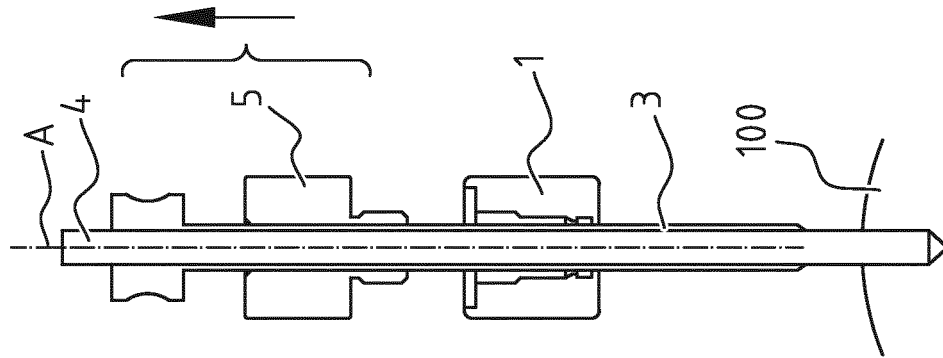

FIG. 2D

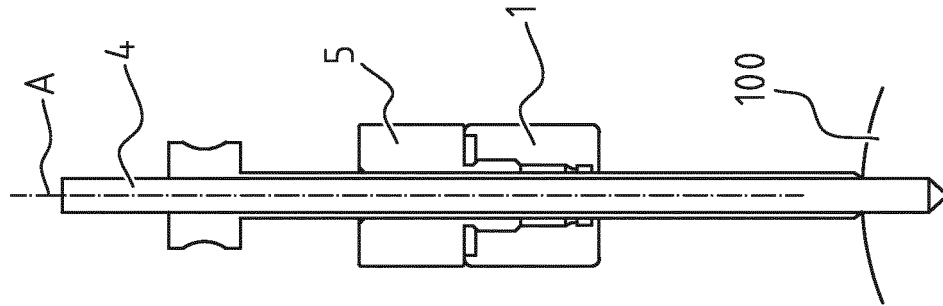

FIG. 2C

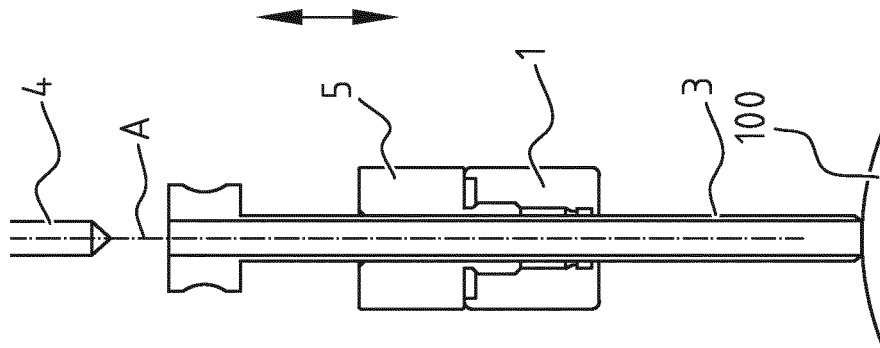

FIG. 2B

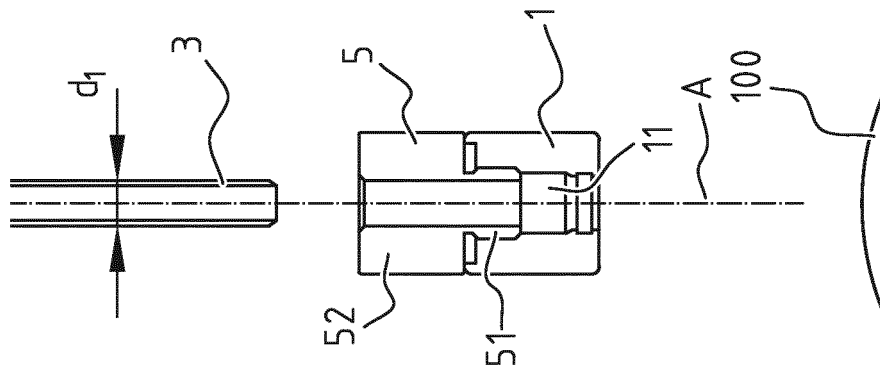

FIG. 2A





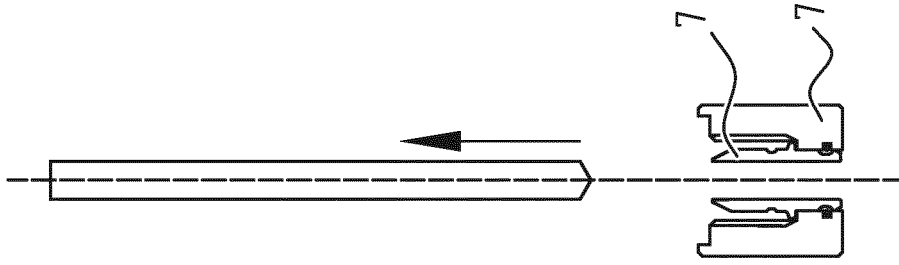

FIG. 4D

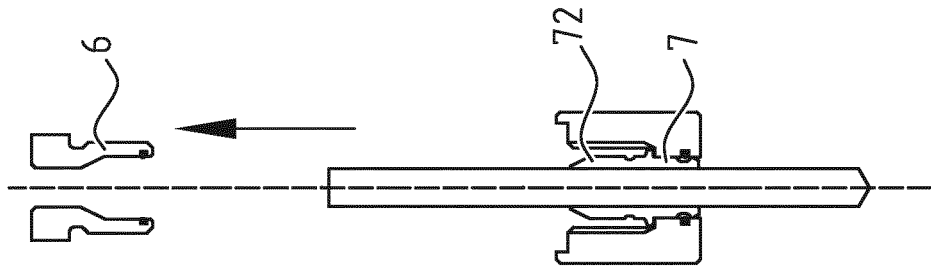

FIG. 4C

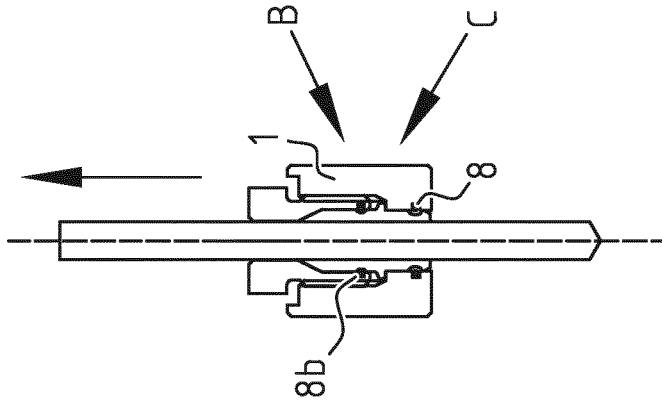

FIG. 4B

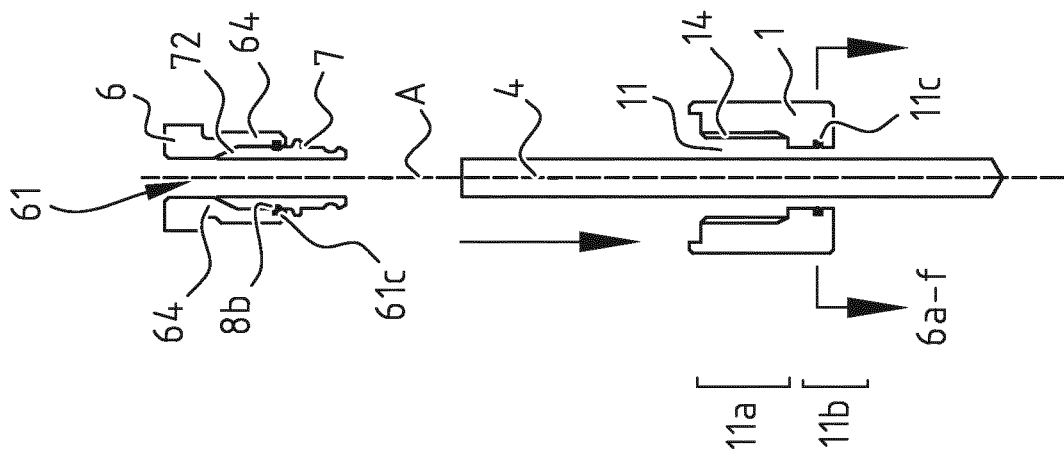

FIG. 4A

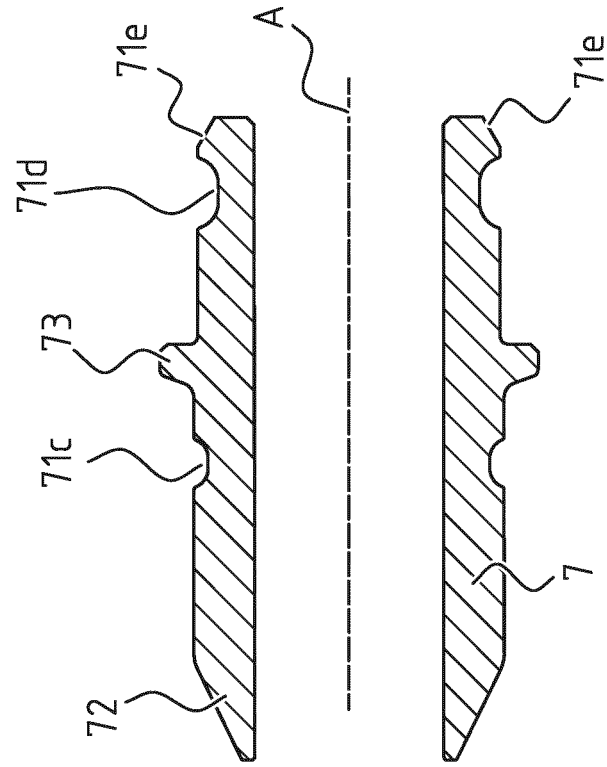

FIG. 5B

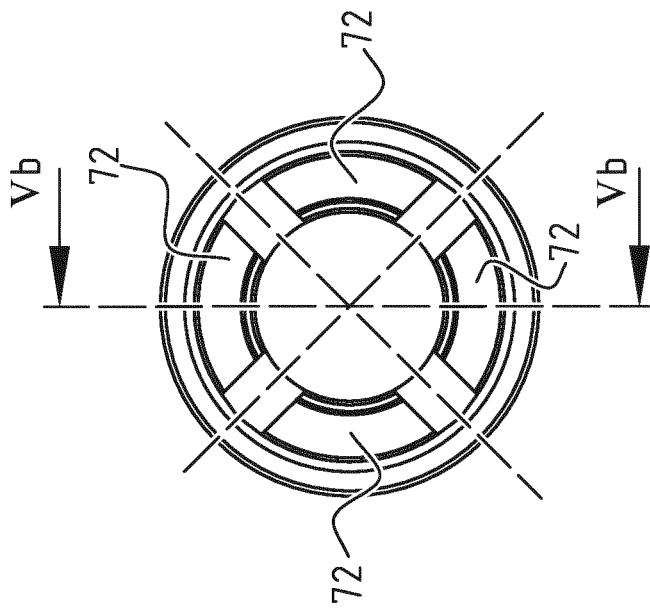
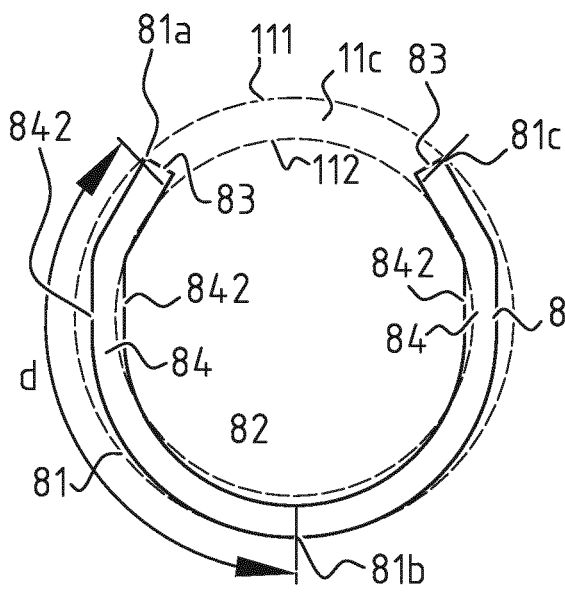
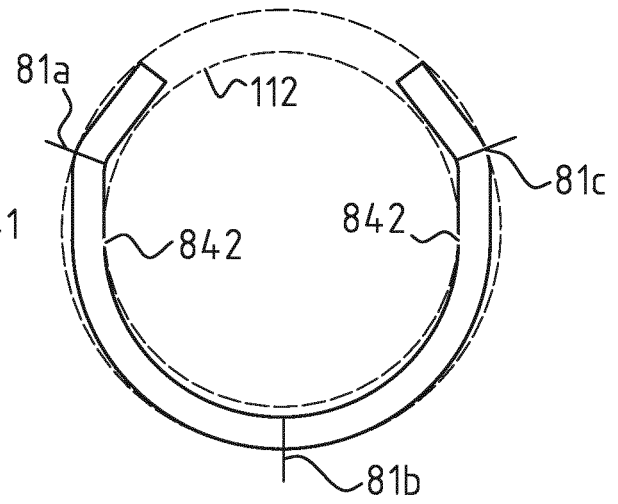

FIG. 5A

6/8



**FIG. 6A**



**FIG. 6B**

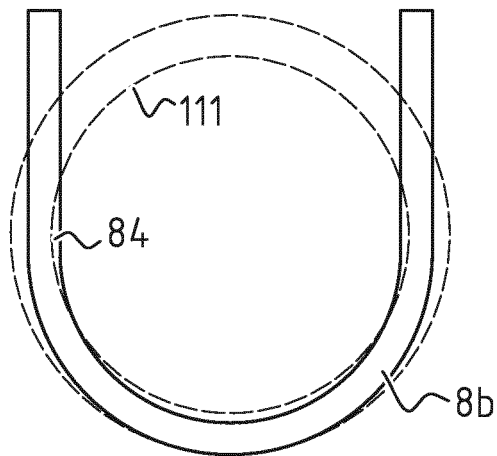

**FIG. 6C**

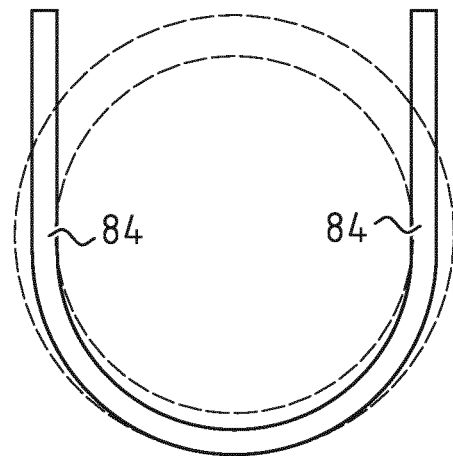

**FIG. 6D**

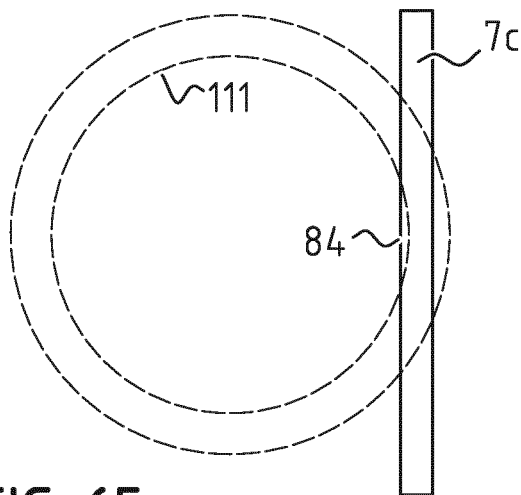

**FIG. 6E**

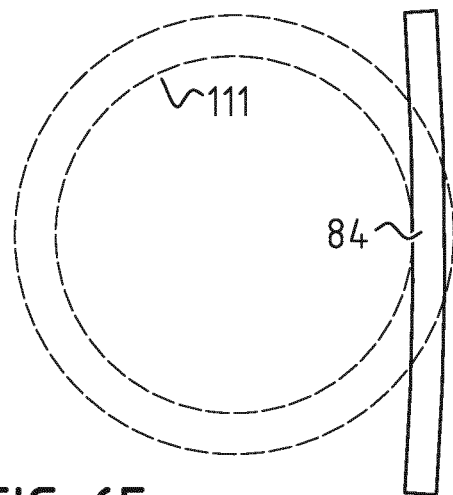

**FIG. 6F**

7/8

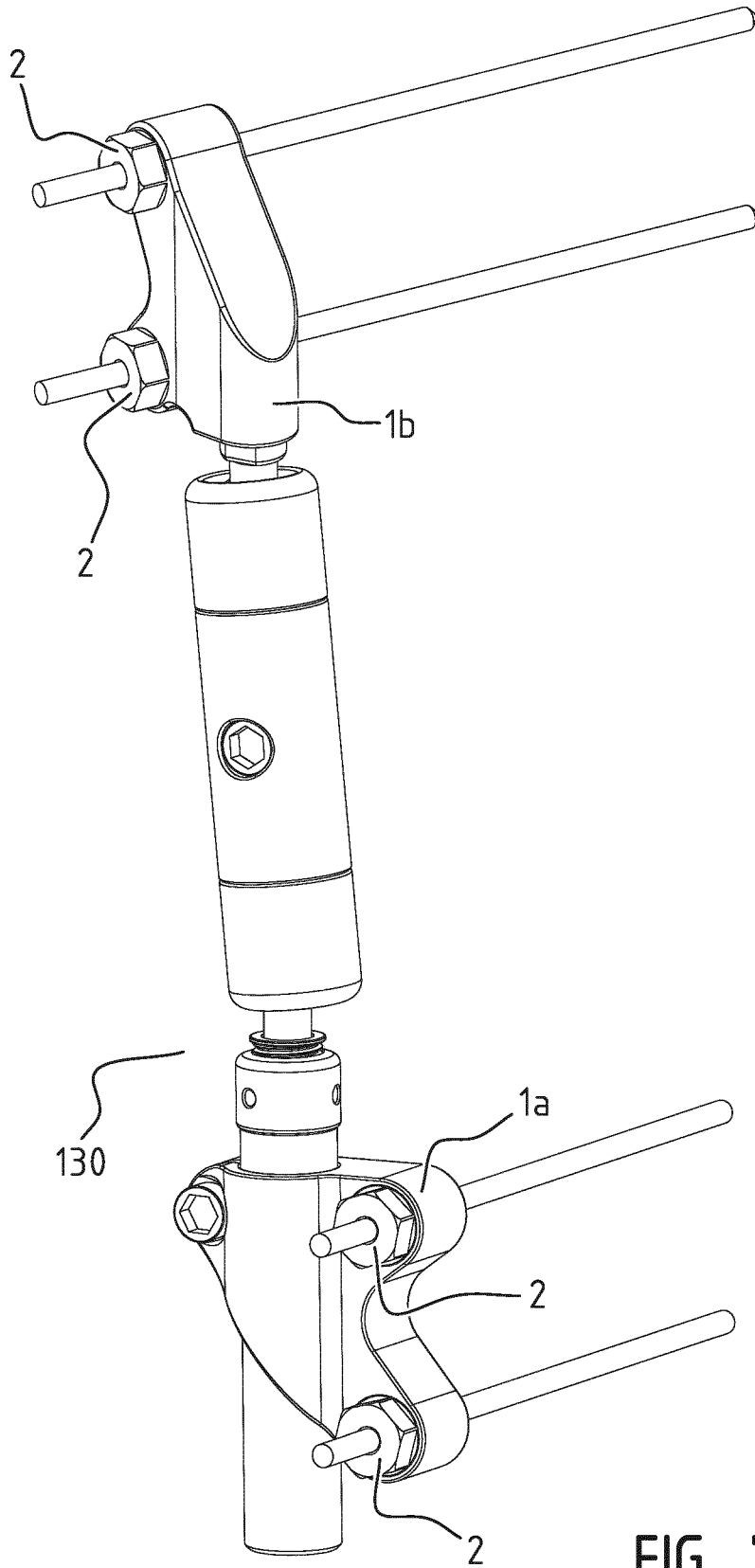
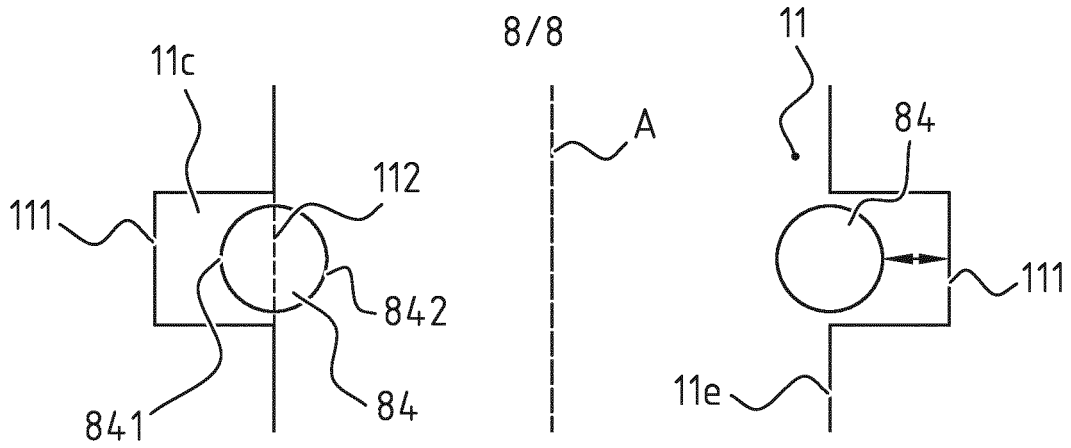
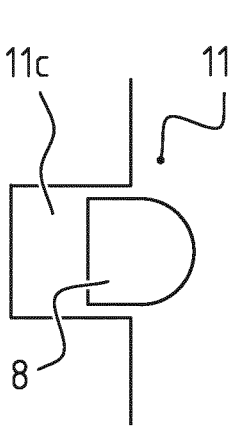

FIG. 7



**FIG. 8**



**FIG. 9A**

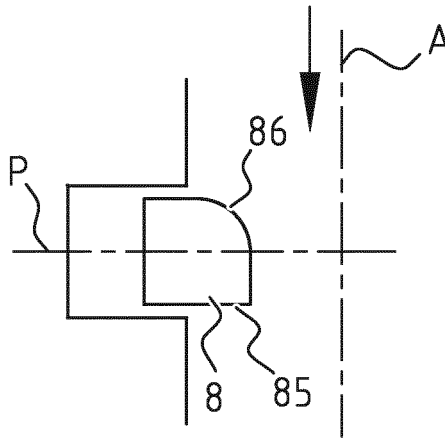

**FIG. 9B**

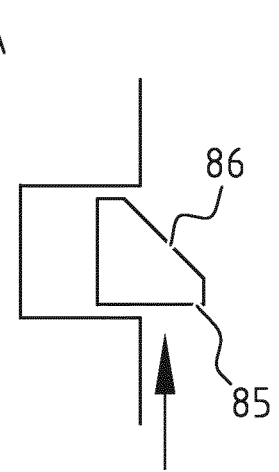

**FIG. 9C**

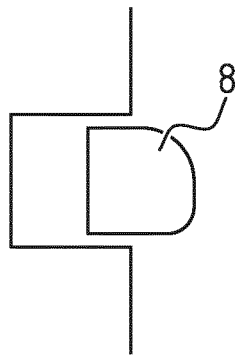

**FIG. 9D**

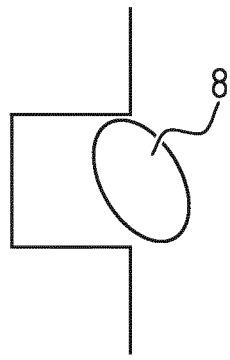

**FIG. 9E**

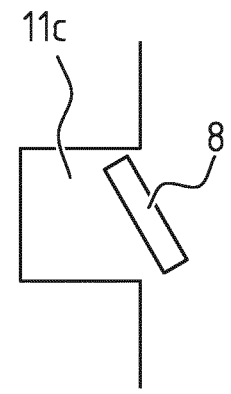

**FIG. 9F**

**INTERNATIONAL SEARCH REPORT**

International application No  
PCT/EP2018/052058

**A. CLASSIFICATION OF SUBJECT MATTER**  
INV. A61B17/64  
ADD.  
  
According to International Patent Classification (IPC) or to both national classification and IPC

**B. FIELDS SEARCHED**  
Minimum documentation searched (classification system followed by classification symbols)  
A61B

Documentation searched other than minimum documentation to the extent that such documents are included in the fields searched

Electronic data base consulted during the international search (name of data base and, where practicable, search terms used)  
EPO-Internal

**C. DOCUMENTS CONSIDERED TO BE RELEVANT**

Category*	Citation of document, with indication, where appropriate, of the relevant passages	Relevant to claim No.
X,P	WO 2017/016611 A1 (UMC UTRECHT HOLDING BV [NL]) 2 February 2017 (2017-02-02) cited in the application figures 1A-4	1-26
X	US 2012/253410 A1 (TAYLOR KYLE [US] ET AL) 4 October 2012 (2012-10-04) figures 13-24	1-4,15, 26

Further documents are listed in the continuation of Box C.

See patent family annex.

\* Special categories of cited documents :

- "A" document defining the general state of the art which is not considered to be of particular relevance
- "E" earlier application or patent but published on or after the international filing date
- "L" document which may throw doubts on priority claim(s) or which is cited to establish the publication date of another citation or other special reason (as specified)
- "O" document referring to an oral disclosure, use, exhibition or other means
- "P" document published prior to the international filing date but later than the priority date claimed

- "T" later document published after the international filing date or priority date and not in conflict with the application but cited to understand the principle or theory underlying the invention
- "X" document of particular relevance; the claimed invention cannot be considered novel or cannot be considered to involve an inventive step when the document is taken alone
- "Y" document of particular relevance; the claimed invention cannot be considered to involve an inventive step when the document is combined with one or more other such documents, such combination being obvious to a person skilled in the art
- "&" document member of the same patent family

Date of the actual completion of the international search  25 April 2018	Date of mailing of the international search report  04/05/2018
--	--

Name and mailing address of the ISA/ European Patent Office, P.B. 5818 Patentlaan 2 NL - 2280 HV Rijswijk Tel. (+31-70) 340-2040, Fax: (+31-70) 340-3016	Authorized officer  Hamann, Joachim
--	---

# INTERNATIONAL SEARCH REPORT

Information on patent family members

International application No

PCT/EP2018/052058

Patent document cited in search report	Publication date	Patent family member(s)	Publication date
WO 2017016611	A1	02-02-2017	NONE
US 2012253410	A1	04-10-2012	AU 2012225496 A1 24-10-2013
			AU 2016277681 A1 19-01-2017
			CA 2866359 A1 13-09-2012
			CN 103517677 A 15-01-2014
			CN 107397582 A 28-11-2017
			EP 2526196 A2 28-11-2012
			JP 6040172 B2 07-12-2016
			JP 2014514024 A 19-06-2014
			JP 2016179268 A 13-10-2016
			US 2012253410 A1 04-10-2012
			US 2016175012 A1 23-06-2016
			WO 2012122317 A2 13-09-2012